

# **PREDICTION OF STRESS GENERATED AT INSOLE SUB-SYSTEM OF DIABETIC FOOT ULCER OFFLOADING DEVICE USING FULL FACTORIAL DOE**

A PROJECT REPORT

submitted by

**NAMEER NAJEEB**

**TKM20MECI09**

to

the APJ Abdul Kalam Technological University

in partial fulfillment of the requirements for the award of the Degree

of

*Master of Technology*

In

*Computer Integrated Manufacturing.*



**Department of Mechanical Engineering**

**TKM College of Engineering Kollam**

**SEPTEMBER 2022**

## DECLARATION

I, Nameer Najeeb, hereby declare that the project report “Prediction of stress generated at insole-system of diabetic foot ulcer offloading device using full factorial DOE.” submitted for partial fulfillment of the requirements for the award of degree of Master of Technology of the APJ Abdul Kalam Technological University, Kerala is a bonafide work done by me under supervision of Subhash N. N., Scientist/Engineer Department of Medical Device Engineering SCTIMST Govt of India, Prof. Kannan S., Assistant Professor, Department of Mechanical Engineering, TKM College of Engineering, Kollam. This submission represents my ideas in my own words and where ideas or words of others have been included, I have adequately and accurately cited and referenced the original sources. I also declare that I have adhered to ethics of academic honesty and integrity and have not misrepresented or fabricated any data or idea or fact or source in my submission. I understand that any violation of the above will be a cause for disciplinary action by the institute and/or the University and can also evoke penal action from the sources which have thus not been properly cited or from whom proper permission has not been obtained. This report has not been previously formed the basis for the award of any degree, diploma or similar title of any other University.

Kollam

16/09/2022

Signature

NAMEER NAJEEB

**DEPARTMENT OF MECHANICAL ENGINEERING**  
**TKM COLLEGE OF ENGINEERING, KOLLAM**



**CERTIFICATE**

This is to certify that the report entitled '**PREDICTION OF STRESS GENERATED AT INSOLE-SYSTEM OF DIABETIC FOOT ULCER OFFLOADING DEVICE USING FULL FACTORIAL DOE**' submitted by '**NAMEER NAJEEB (TKM20MECI09)**' to the APJ Abdul Kalam Technological University in partial fulfillment of the requirements for the award of the Degree of Master of Technology in Computer Integrated Manufacturing, Mechanical Engineering is a bonafide record of the project work carried out by him under my guidance and supervision. This report in any form has not been submitted to any other University or Institute for any purpose.

Internal Supervisor: **Prof. Kannan S.**  
Assistant Professor  
Department of Mechanical Engineering  
TKM College of Engineering, Kollam

External Supervisor: **Er. Subhash N. N.**  
Scientist/Engineer  
Department of Medical Device Engineering  
SCTIMST, Govt. of India

PG Coordinator: **Prof. Kannan S.**  
Assistant Professor  
Department of Mechanical Engineering  
TKM College of Engineering, Kollam

**Dr. Dileep P. N.**  
Head of Department  
Department of Mechanical Engineering  
TKM College of Engineering, Kollam

## ACKNOWLEDGEMENT

First of all, I am indebted to the **God Almighty** for giving me an opportunity to excel in my efforts to complete this project on time.

I am extremely grateful to **Dr. T. A. Shahul Hameed**, Principal, TKM college of Engineering and **Dr. Dileep P. N.**, Head of the Department, Department of Mechanical Engineering, for providing all required resources for successful completion of my project.

I am greatly obliged to my external supervisor **Er. Subhash N. N.**, Scientist/Engineer, Department of Medical Devices Engineering SCTIMST Govt of India, for his encouragement, guidance and support.

I am greatly obliged to my internal supervisor **Prof. Kannan S.**, Assistant Professor, Department of CIM, for his encouragement, guidance and support. My heartfelt gratitude to **Prof. Kannan S.**, PG coordinator, Department of CIM & **Prof. Faizal N. S.**, Assistant Professor, Department of CIM for their valuable suggestions and guidance in the preparation of the project presentation and report.

I express my thanks to all Faculties and Technical staffs, Department of Mechanical Engineering, and all staff members and friends for all help and coordination extended in bringing out this project successfully in time.

I will be failing in duty if I do not acknowledge with grateful thanks to the authors of the references and other literatures referred to in this project.

Last but not the least, I am very much thankful to my parents who guided me in every step which I took.

Kollam

16/09/2022

**NAMEER NAJEEB**

## **ABSTRACT**

Diabetes is one of the metabolic diseases. Uncontrolled diabetes can lead to diabetic foot ulcers and if it is not treated further it would lead to amputation. Foot ulcer patients are prescribed with Diabetic Foot Ulcer Offloading devices like walkers etc. by doctors. Here in this study we focus on developing an insole sub- system and predict the insole pressures using the full factorial DOE, in initial phase a 3-layer insole with different materials was modelled, and material combinations was to be found hence 3 different combinations were simulated and best stress reducing insole combination was selected as the insole. The control factors were selected and the datas were given to the statistical software Minitab, were 16 DOE's were to be analysed, which was performed in Ansys. The insole combinations showed a stress reduction of about 43% with barefoot and the statistical software provide the effectiveness and interactions of the diiferent control factors on each outputs variations and the final regression equation predicted the outputs (stress) values of different control factors, which were validate again after cross verification.

Keyword: Insoles, Diabetes, Three-layered insole, Hyper elastic, 3D FEM, Minitab, Offloading.

# CONTENTS

<b>Title</b>	<b>Page No.</b>
ACKNOWLEDGEMENT	i
ABSTRACT	ii
LIST OF TABLES	v
LIST OF FIGURES	vii
ABBREVIATIONS	viii
CHAPTER 1. INTRODUCTION	1
1.1 PATHOPHYSIOLOGY	2
1.1.1 ISCHEMIA	2
1.1.2 NEUROPATHY	3
1.2 RISK FACTORS OF DFU	5
1.3 COMPLICATIONS OF DFU	6
1.3.1 SOFT TISSUE ABNORMALITIES	6
1.3.2 OSTEOMYELITIS	6
1.3.3 AMPUTATION	6
1.3.4 DEATH	7
1.3.5 TREATMENT	7
1.3.6 DEBRIDEMENT	7
1.3.7 WOUND DRESSING	7
1.3.8 PRESSURE OFFLOADING	8
1.4 OFFLOADING DEVICES	8
1.4.1 FIBERGLASS TOTAL CONTACT CASTING	8
1.4.2 REMOVABLE CAST WALKER	9
1.4.3 IRREMOVABLE CAST WALKER	10
1.4.4 HALF SHOES	10
1.4.5 HEALING SANDAL	10
1.4.6 FELTED FOAM	11
1.4.7 CRUTCHES, CRANES, WALKER, WHEELCHAIRS	11
1.4.8 SURGICAL	12
CHAPTER 2. LITERATURE REVIEW	13

2.1 OBJECTIVES	18
CHAPTER 3. METHODOLOGY	19
3.1 CONCEPT	20
3.2 DEFINITION	24
3.2.1 FISHBONE DIAGRAM	25
3.2.2 P-DIAGRAM	26
3.3 DESIGN AND DEVELOPMENTS	28
3.3.1 CAD MODELING	30
3.3.2 PRE-PROCESSING	31
i. Meshing	31
ii. Boundary Condition	33
iii. Modeling Contacts	34
iv. Material Selection	37
v. Material Properties	39
3.4 FINITE ELEMENTAL ANALYSIS	41
3.5 POST PROCESSING	42
CHAPTER 4. RESULTS	46
4.1 STRESS	47
4.2 STRAIN	51
4.3 DEFORMATION	55
Chapter 5. CONCLUSION	60
REFERENCES	61

## LIST OF FIGURES

<b>No.</b>	<b>Title</b>	<b>Page Number</b>
Fig.1.1	Pathway of DFU.	2
Fig.3.1	Methodology.	19
Fig.3.2	System level discretization.	21
Fig.3.3	Benchmarking	25
Fig.3.4	Fishbone Diagram	26
Fig.3.5	P- Diagram	27
Fig.3.6	Cad Models.	30
Fig.3.7	Mesh Quality.	32
Fig.3.8	Mesh Elements	33
Fig.3.9	Different Mesh Sizes	33
Fig.3.10	Force and Support	34
Fig.3.11	Contacts	35
Fig.3.12	Different contacts illustrated	36
Fig.3.13	Stress-Strain Graph of Materials	40
Fig.3.14	Curve Fitting Using Ansys	40
Fig 3.15	Stress FEA results	44
Fig 3.16	Stress Comparison	44
Fig.3.17	Heel Stress	45
Fig.4.1	Pareto Chart of Stress	48
Fig.4.2	Main Effects plot of Stress	49

Fig.4.3	Interaction Plot of stress	50
Fig. 4.4	Pareto Chart of Strain	52
Fig. 4.5	Interaction Plot of strain	53
Fig. 4.6	Main Effects plot of Strain	54
Fig. 4.7	Pareto Chart of Deformation	57
Fig. 4.8	Interaction Plot of Deformation	57
Fig. 4.9	Main Effects plot of Deformation	58

## **LIST OF TABLES**

<b>No.</b>	<b>Title</b>	<b>Page Number</b>
Table 1.1	Ulcers	5
Table 3.1	Design Space	28
Table 3.2	Control Factors	29
Table 3.3	Skewness Value	32
Table 3.4	Materials of Different Layers	38
Table 3.5	Skin material properties	39
Table 3.6	Material Properties of Insole Materials	41
Table 3.7	Control Factors Results	46

## ABBREVIATIONS

DFU- Diabetic Foot Ulcer

DPN- Diabetic peripheral neuropathy

TCC- Total contact casting

RCW- Removable cast walker

ICW- Irremovable cast walker

PAD- Peripheral arterial disease

DM- Diabetes mellitus

IDF- International Diabetes

Federation

PPP- Peak Plantar Pressure

Pf- Polyfoam

PLZ- Plastazote

EVA- Ethyl Vinyl Acetate

PU- Polyurethane

DOE- Design of Experiments

VOI- Volume of Interest

FMEA- Failure Mode Effective

Analysis

R - Response

S- Standard Deviation

FEA- Finite Elemental Analysis

FEM- Finite Elemental Method

CIM- Computer Integrated Manufacturing

CAD- Computer Aided Design

# **CHAPTER 1**

## **INTRODUCTION**

Diabetes-related foot ulcers (DFUs) are a frequent and dangerous complication of chronic hyperglycemia. Uncontrolled diabetes-related hyperglycemia can cause diabetic peripheral neuropathy (DPN), which is most common in the feet and legs. DPN causes broad pain, numbness, loss of sensation, and nerve degeneration, which might delay the identification and diagnosis of DFU. Diabetes also contributes to vascular illness and may change the blood flow to nutrients, with ischemia increasing the risk of developing ulcers. Patients are unable to react to repeated stress and trauma to their plantar tissues because of their loss of sensation and reduced metabolic response, which can result in skin damage and sores. Due to the increased load, diabetic patients who also have obesity may suffer additional stress to the wound site.

A complete care plan is used to treat DFU, and it includes pressure offloading, wound debridement, infection therapy, and revascularization treatments if needed. By lowering external pressure, delaying skin pressure, and shielding the wound site to minimise repetitive damage, offloading devices are used to promote therapeutic success and healing. Total contact casting (TCC), removable cast walker (RCW), irremovable cast walker (ICW), half-shoe, healing sandal, therapeutic footwear, felted foam, and mobility aids are available offloading device alternatives.

## 1.1 PATHOPHYSIOLOGY

Diabetic foot ulcer pathogenesis is complicated, comprising a variety of variables such as neuropathy, ischemia, foot deformities, and increased foot pressures (Figure 1). However, neuropathy, ischemia, or a mix of the two are the key etiological causes.

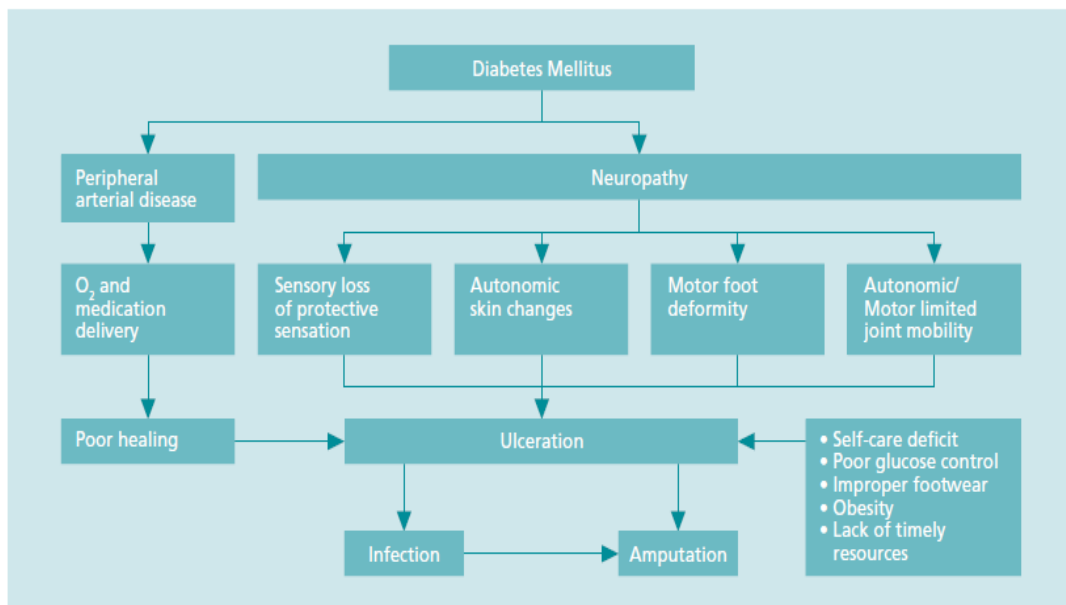

Figure 1.1 Pathway to diabetic foot ulcers

### 1.1.1 Ischemia

Peripheral artery disease (PAD), which is defined by ischemia in the lower limbs and affects up to 30% of diabetes patients, affects nearly half of those who develop diabetic foot ulcers. Only 15% of people with diabetic foot ulcers develop purely ischemic ulcers. Due to the reduced supply of blood, nourishment, and oxygen to the wound, the body's normal response to foot ulcerations is compromised by the presence of ischemia, which results in non-healing ulcers. This speeds up the spread of infection and encourages tissue

degradation. In addition to delaying recovery, PAD also makes recurrence and amputation more likely.

### **1.1.2 Neuropathy**

For the pathophysiology of diabetic neuropathy, two theories have been put forth. These include the Maillard reaction and preventing the formation of nitric oxide. The former involves an increase in intracellular proteins' non-enzymatic glycation, which produces advanced glycation end products. These products can change the characteristics of the structural proteins in peripheral neurons, leading to nerve degeneration and impairing nerve regeneration.

The endothelial nitric oxide synthase is inhibited in the nitric oxide mechanism, which stops the generation of nitric oxide. A powerful endogenous vasodilator and inhibitor of platelet aggregation is nitric oxide. Additionally, it controls how proteins involved in atherogenesis are expressed in the tiny blood arteries that supply the peripheral nerves.

The most prevalent type of neuropathy is peripheral sensory neuropathy, which causes pain sensitivity and eliminates the signals that alert the patient to impending or ongoing tissue harm. The foot is additionally subjected to increased, continuous pressure, which damages the tissue and causes ulcers. Due to the lack of sweat and oil gland function, autonomic neuropathy may increase the risk of dryness, fissuring, and infection in the foot. Motor neuropathy weakens and atrophies the intrinsic foot muscles, which can lead to various anatomical abnormalities such as clawing of the toes and plantar flexion of the metatarsal heads. Motor neuropathy or other structural foot deformities such as flatfoot,

hallux valgus, claw toes, and hammer foot can cause anatomical deformities that restrict joint mobility and are ulcer-prone pressure points and calluses on the sole of the foot, especially on the forefoot or the surfaces of bony prominences. For tissue disintegration to occur, trauma is necessary. This can be extrinsic from improperly fitting shoes or intrinsic from repeated pressure and/or calluses.

## 1.2 RISK FACTORS FOR DIABETIC FOOT ULCERS

Risk factors for DFUs include:

- PAD causing critical limb ischemia
- Combination of diabetic neuropathy, deformity, callus, and elevated peak skin pressure
- Penetrating trauma
- Ill-fitting shoes, or friction induced skin trauma
- History of previous ulcers
- Poor glycemic control
- Cigarette smoking
- Male gender
- Social factors e.g., low socioeconomic status, lack of access to healthcare services, and poor education

Table 1.1 Ulcers

Feature	Neuropathic	Ischemic	Neuroischemic
Sensation	Sensory loss	Pain	Degree of sensory loss
Callus/necrosis	Callus present and often thick	Necrosis common	Minimal callus; prone to necrosis
Wound bed	Pink and granulating, surrounded by callus	Pale and sloughy with Poor granulation	Poor granulation
Foot temperature and pulses	Warm with bounding pulses	Cool with absent pulses	Cool with absent pulses
Other	Dry skin and fissuring	Delayed healing	High risk of infection
Typical location	Weight-bearing areas of the foot, such as metatarsal heads, the heel and over the dorsum of clawed toes	Tips of toes, nail edges and between the toes and lateral borders of the foot	Margins of the foot and toes
Prevalence	35%	15%	50%

## **1.3 COMPLICATIONS OF DIABETIC FOOT ULCERS**

### **1.3.1 Soft Tissue Abnormalities**

Soft tissue edema, cellulitis, abscesses, sinus tracts, tenosynovitis, joint effusions, and arthritis are some of the typical side effects of infection. Because of the differences in these entities' management, it is crucial to differentiate between them.

### **1.3.2 Osteomyelitis**

Osteomyelitis is a soft tissue infection that spreads into the bone by first affecting the cortex and subsequently the marrow and is the outcome of non-healing ulcers. Osteomyelitis can infect any bone, although the forefoot (90%) and midfoot (5%) are the most commonly affected, followed by the hindfoot (5%). On bone biopsy, osteomyelitis characteristics are present in 82% of moderately deep ulcers and in all ulcers that expose the bone.

### **1.3.3 Amputation**

Amputation is a consequence of failure to manage DFUs, which may be necessary in patients with soft tissue necrosis, osteomyelitis, uncontrollable infection, or intractable pain.

### **1.3.4 Death**

Patients with DFUs leads to amputation. These amputations may further results in increased mortality rates in extreme conditions that occurs rarely.

### **1.3.5 Treatment**

The treatment of DFUs should be part of a comprehensive care plan that includes debridement of the wound, treatment of infection, revascularization procedures when indicated, and pressure offloading.

### **1.3.6 Debridement**

Debridement involves the removal of necrotic and non-viable ulcer tissue in order to improve healing, by facilitating the formation of granulation tissue. It should be done as often as necessary and can be achieved surgically, enzymatically, mechanically, biologically, and by autolysis. Surgical debridement using a scalpel, the sharp method, is the quickest and most efficient way of removing necrotic tissue. A successful debridement is marked by a healthy bleeding ulcer bed.

### **1.3.7 Wound Dressing**

After debridement, clinicians should base dressing selection on the wound's location, size and depth, amount of exudate, presence of infection or necrosis and the condition of the surrounding tissue to maintain a moist wound bed.

### **1.3.8 Pressure Offloading**

Off-loading facilitates the healing of plantar ulcers by relieving the ulcers of sustained pressure. Pressure offloading methods include, total contact casting (TCC), removable and irremovable cast walkers, half shoes and felted foam dressing.

## **1.4 OFFLOADING DEVICES**

Offloading devices are used to achieve therapeutic success and healing by reducing external pressure, deferring skin pressure, and by protecting the wound site to prevent repetitive trauma. In order to reach acceptable healing rates, the appropriate device may be based on a combination of mechanical protection, patient need, and adherence.

### **1.4.1 Fiberglass Total Contact Casting**

TCCs are non-removable, custom-made casts that are put by skilled medical personnel. A TCC spreads the direct forces that would be given to any one place across the length of the cast by stretching from the distal toes, across the bony prominences of the metatarsal heads and bony midfoot, and beyond the back of the heel. To protect wounds from direct trauma and stop the mechanism that started ulcerative growth, direct force pressure is transferred up the posterior cast wall. TCC must be used and changed every one to two weeks in order to stop skin lesions from getting worse, further tissue damage, and soft-tissue infection. TCC does not permit frequent wound inspections or dressing

changes and therefore substantial wound seepage is a contraindication for TCC. It is also contraindicated in the presence of untreated ischemia and infection or osteomyelitis, and in patients with severe PAD.

#### **1.4.2 Removable Cast Walkers**

Removable cast walkers (RCW) are removable casts with a rocker bottom base that maintains the ankle at a 90-degree angle and a protective inner sole. They are thin and have a protective, semi-rigid shell that helps to support the limb. The foot base is sufficiently broad to accommodate dressings. The removability enables quick application and removal of wound care by patients or medical workers. Some RCWs contain additional layers of foam or other soft materials to ensure entire contact, while others have overlapping air cells that provide occasional pneumatic compression to reduce edoema. RCWs, however, are not created to order, therefore not all patients, especially those with shorter legs, large feet, or severe abnormalities, may be able to wear them. 20 Wearing of this gadget by patients as instructed

A RCW can be anything, like a Scotchcast boot. Plaster is replaced with Scotchcast, resulting in a lighter method. The Scotchcast boot is a well-padded cast that has had the cast over the dorsum of the foot cut away, allowing it to be either removable or nonremovable. A closure is created using padding, tape, and fabric straps with hook and loop fasteners. When necessary, windows are cut to cover the sores, and removable fibreglass heel caps are fitted for severe heel ulcers. To enhance patient modality while yet shielding the ulcer from pressure, the boot is worn with a cast sandal.

### **1.4.3 Irremovable Cast Walkers/Instant Total Contact Cast**

Walkers with an irremovable cast (ICW), also referred to as an instant total contact cast (iTCC), are hybrid devices that combine a TCC's semi-permanent binding and RCW's frame. An RCW can benefit from the better-tolerated offloading capacity of an RCW combined with total adherence of a TCC by being wrapped in composite fibres like fibreglass or layers of cohesive tape. For patients with severe ischemia, this device makes it possible to evaluate the wound frequently because it can be removed and reapplied more easily.

### **1.4.4 Half Shoe**

Half-shoes allow a heel-midfoot and toe-off gait pattern to be fully utilised while reducing dependency on the forefoot. They have a rigid, rocker-bottom sole with a specially designed above-ankle bracing. The front of the shoe is removed, leaving the heel and midfoot as the only surfaces capable of supporting weight. Although pricey and simple to use, this personalised equipment needs time and expertise to be created to meet the needs of the patient.

### **1.4.5 Healing Sandal**

To give a better distribution of metatarsal head pressures as an offloading alternative, a rigid rocker can be added to a sandal's sole. The tool is portable, sturdy, and reusable, but it takes time and expertise to create the rigid-sole rocker design and other adjustments to

meet the patient's demands. A product called the "mabal shoe" combines the benefits of RCWs and therapeutic sandals by increasing touch with the foot. Another removable fibreglass combi-cast shoe with limited cushioning and a stiff sole that completely contacts the plantar area is a Mabal cast shoe. A soft cast part extends to just below the ankle, leaving the ankle mobile. A plastic roller sandal is worn underneath the shoe to facilitate walking.

#### **1.4.6 Felted Foam**

A bilayered felted foam pad is fixed over the plantar aspect of the foot that corresponds to the ulcer site. This offloading method is only recommended if other forms of biomechanical relief are not available and is recommended to be used in combination with appropriate footwear.

#### **1.4.7 Crutches, Canes, Walkers, Wheelchairs**

These aids can assist in offloading a foot to speed up the healing of a diabetic lesion. However, they call for power and strength in the upper body. Due of the lack of compulsory adherence, the effectiveness of offloading would depend on usage consistency. Another drawback is that by applying more pressure to the unaffected side, assistive devices can increase the risk of ulceration on the limb on the opposite side. These tools are used by some patients to help immobilise ambulatory modalities like TCC. When returning to normal, these devices can also assist with the gradual start of weight-bearing.

### **1.4.8 Surgical**

When conservative treatment is unsuccessful, surgical offloading can be utilised to treat diabetic foot issues. Joint arthroplasty, single or pan metatarsal head excision, or osteotomy can encourage healing and avoid a recurrent foot ulcer. Exostectomy and tendon lengthening are two other operations that can help decrease bone strain by lowering forefoot pressure and enhancing alignment of the ankle, rear foot, midfoot, and forefoot.

## CHAPTER 2

### LITERATURE REVIEW

Diabetes mellitus, more often known as diabetes, is a dangerous, long-term (or "chronic") disorder that appears as elevated blood glucose levels, when the body is unable to create any, sufficient amounts of, or utilize the insulin that is produced. The prevalence of diabetes mellitus (DM) has been reported to increase every year. Uncontrolled DM will increase morbidity, mortality, and economic burdens. (1) The International Diabetes Federation (IDF) Diabetes Atlas 2021 reports that, Diabetes is predicted to affect 537 million people worldwide in 2021, and 643 million by 2030 and 783 million by 2045. Additionally, it was anticipated that 541 million individuals would have reduced glucose tolerance by year end. Over 6.7 million persons between the ages of 20 and 79 were anticipated to pass away in the same year as a result of diabetes-related diseases. Every year, more kids and teenagers (i.e., those under the age of 19) are diagnosed with diabetes. More than 1.2 million kids and teenagers had diabetes. Diabetes presently had direct health costs close to \$1 trillion USD, and by 2030, these costs might be even higher. (2) The interventions taken into consideration, which are frequently used in clinical settings around the world, include casting techniques such as Total Contact Cast (TCC) and Cast Shoes, footwear-related techniques such as shoes, insoles, in-shoe orthoses, socks, and surgical offloading techniques such as silicone injections/tissue augmentation, callus debridement, metatarsal head resection, osteotomy/arthroplasty/ostectomy/Exostectomy. Other offloading strategies include bed rest, wheelchairs or crutches, bracing (ankle-foot orthoses or patella tendon bearing), walkers, Airca st pneumatic walker, offloading dressings, felted foam or padding, and plugs.(3,4)Patients with active ulcers or those

without active ulcers but with significant plantar pressure were advised for insoles to relieve pressure. Currently employed in clinical settings also include detachable cast walkers, and offloading devices with removable plugs like the Darco International Inc. Peg-Assist Insole and the DH Pressure Relief Walker. Although whole contact casts are now the industry standard for relieving wound pressure by load transfer and pressure redistribution, more affordable and straight forward alternatives may potentially be useful in clinical situations. (5,6)

Material selection for the insole was one of the paramount importance in the design. Typically, EVA, Poron, Plastazote are commonly used among commercial products. (6) The ability of the ethylene-vinyl acetate (EVA), Poron, Plastazote, and polyurethane to lower PPP in the plantar region led to the development of these materials. The insole performs a variety of tasks including cushioning, resiliency, and stiffness. Insoles made of EVA have been used in the forefoot, midfoot, and rearfoot plantar regions. Single EVA foam-based material proved excellent for absorbing energy to help the lowering of rearfoot pressure. Furthermore, a foam-based insole made of a combination of EVA and Poron was said to be great for supporting the arch and maximizing insole plugs. By detaching the square plugs from the insole, the PPP in the forefoot area may be adjusted. Furthermore, Plastazote and Polyurethane (PU) were found to be appropriate materials for pressure distribution in a multi-layer shoe's forefoot and rearfoot. (7). In Rogers et al the effect of poron and plastazote on insole was compared and poron was recommended as it has high elastic memory property compared with plastazote hence resist deformation from repeated loading and maintain peak pressure reduction throughout.

Design of manufacturability has to be also considered while developing an insole. The different layers of insole may contain different materials accordingly like EVA, Plastazote, Poron etc. In certain studies, it was found that CNC milling was used to create the required shape from the available foam material. The different foam materials can be available from different manufactures commercially according to specifications and application or purpose of each. (8,9)

Total contact insoles increase the efficiency of offloading devices by distributing pressure more evenly. Unfortunately, these insoles cannot be adjusted or specifically shaped to the patient's foot or a positive cast. Due to time and money restrictions, standard multi-laminate insoles are rarely moulded. (1) Although multi-laminate insoles lack an inherent capacity to unload, they have the capability to mould or adapt over time. They are, at best, smart cushioning devices without shaping. Some commercial offloading devices have insoles with removable hexagonal, square, or diamond-shaped plugs to selectively unload certain areas of the foot. Examples of these insole systems include the plug insole system used by the Ossur<sup>TM</sup> Active Offloading Walker (formerly the DH Walker), the Darco Peg Assist<sup>TM</sup> system, and the Donjoy MaxTrax<sup>TM</sup> Diabetic Walking Boot. Although thin soles may be able to cushion certain portions of the plantar surface, they are ineffective at properly transferring forces away from high-pressure zones unless they are worn with a shoe that has a rocker sole. The foam material of the MaxTrax<sup>TM</sup> and Donjoy<sup>TM</sup> devices is deep enough to permit complete contact auto-conformation of the insoles. The Darco<sup>TM</sup> and Ossur<sup>TM</sup> devices were found to provide sufficient depth for many flat feet with low arches but did not have the additional depth required to fill the average- or high-arched foot. The Oped vacocast diabetic walker is an alternative to this,

and it features a thick Memory Foam insole that automatically adapts to the plantar sole when sufficient vacuum pressure is applied. (10)

In silico or computational modelling method such as finite element analysis (FEA) is used for analysis driven design of components of insole. Previous in silico studies reported that linear, isotropic material properties are used for offloading materials. In one of the study, 3 orthotic insole structure which include EVA, Polyurethane, Polyethylene in which they assigned linear elastic property. The paper discusses about the magnitude of the deformity and the compressive stress distributed across the regions of the insole made of different combinations of materials. (11) Alternatively, insole materials were also assigned with non-linear isotropic property due to the large deformation behaviour by using a compressible Neo-Hookean or Ogden function material models. (12,13) They developed a method to determine the volume exposure when mechanically loading human heel. They defined the two VOIs as heel and tissue surrounding high risk ulceration and defined bone as isotropic linear – elastic and skin as viscoelastic solid. The papers discussed above the force applied at the time of heel strike was 320N with a specific heel strike angle ranging from 10-20 degree. The study used ISO 22675 standards for obtaining the boundary conditions. (14). In 1997, Lemmon and Shiang published a paper on his study, describing the stress distribution in an insole. He created a two-dimensional finite element model of the insole, in that he used PPT and CLOADCREPE as the materials of the insole. The attribute of the material property has been used as hyperelastic. (11) An insole constructed of EVA was the subject of a linear FEM model presented by Agati and Ladin in 1992. They calculated the plantar pressure distribution using EVA as an elastic, isotropic, and linear material. (12) A three-dimensional nonlinear static model of an insole was created by Ansys software by Barani et al. in 2005. As a single-layer insole, they

looked at 4 different materials. Because it concentrated plantar stress in the least amount, they determined that silicone gel was the best [13]. Petre conducted research in 2006 on a shoe with a 13 mm thick, flat footbed constructed of Poron, Plastozote, and Microcell Puff. FEM software was used to simulate the insoles. Utilizing various materials during pressure testing together with sheared and volume tests [14]. Cheung and Zhang (2008) conducted research on a foot orthotics design parameter to reduce pressure volume using FEM statistical software. Results show that a curved area in touch with the foot has a greater impact on relieving pressure. They are enlightening and effective at lowering pressure [15]. Recently, the foot and insole have been modelled combined in several research. Cheung and Zhang replicated the right foot of a healthy individual during the stance phase while wearing only socks in 2006 using a three-dimensional MRI picture. Additionally, they created a nonlinear insole model using the ABAQUS programme and looked at the insole's stress distribution [16]. A three-dimensional FEM model was used by Jamshidi et al. in 2010 to study the relationship between an ankle-foot orthotic and an insole. They discovered that reducing plantar pressure with an insole might enhance the performance of an ankle-foot orthotic when walking [17]. A three-dimensional model of an insole developed by Poron and appropriate for Stoppage gait problems was simulated by Jamshidi et al. in 2010. In both static and dynamic modes, they retrieved the insole's stress distribution [18]. In 2008, Tammy et al. contrasted a bespoke insole with a typical custom insole comprised of a thin outer cover and hyper elastic material. They discovered that a bespoke footbed with a form that matches the curvature of the plantar surface substantially lessens plantar pressure [19]. Using experimental testing, Lavery et al. (2005) evaluated the shear stress parameter in a three-layer insole consisting of plastazote foam (PLZ), Prone, and EVA. They discovered that this arrangement reduced the shear stress between the foot and the insole [20]. In Ghassemi et al (2015), plantar pressures

were measured and, four hyper elastic materials were selected for their study: silicone, PLZ, EVA foam, and polyfoam (PF). Four samples were prepared for the uniaxial pressure test, which is then conducted to determine the materials' mechanical properties.. A three-dimensional model was then created in the Catia software and sent to the Abaqus software for analysis. The paper compared the single-layer and three-layer insoles in static and dynamic circumstances. The distribution of stress and strain as well as the reduction of stress concentration were studied between these insoles. Following FE analysis and selection of the optimal insole, few samples were created and tested using a Pedar to verify FE results. (2)

## **2.1 OBJECTIVES**

The following are the objectives of this investigative experimental study:

1. To design the insole sub- system of the diabetic foot ulcer offloading device
2. Contact & interactions modeling
3. Design optimization of model
4. To predict the mechanical behavior of insole sub-system using FEA for various materials
5. To predict the stress generated in the insole sub system during heel strike using full factorial DOE.

# CHAPTER 3

## METHODOLOGY

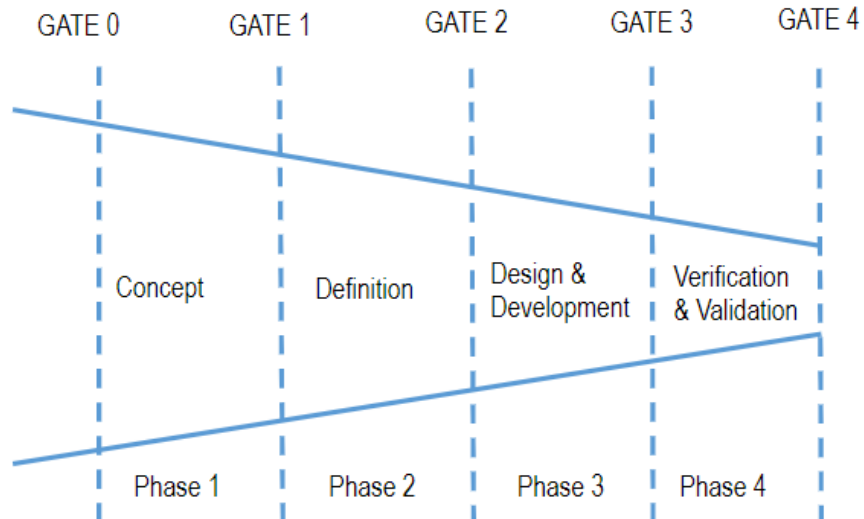

Fig 3.1 Methodology

The exertion starts with the phase of concept development in which existing devices in the market are studied, benchmarking etc which turns out to be the paramount step towards the exertion. The next phase which is definition the project comes immediately after the concept phase, here in this phase the different risk analysis , P-diagram, target specifications in system level and component levels are found out and elaborated etc, the definition design space and control factors. Then the most important phase of the exertion comes into action where the design and development of the new embodiment where the geometric model is created according to the design space in a 3D modeling software. The material properties of the materials are found out using curve fitting using the stress-strain curves from different journals. The different boundary conditions were given including loads, supports, joints, contacts. The material selection for the embodiment, control

factors, simulation and optimization. Then comes the last phase of the project in which the results are verified using existing references and validated.

### **3.1 CONCEPT**

According to National Health Portal (NHP), India has over 60 million diabetics out of a population of 1.3 billion. In India the prevalence of diabetic foot ulcer (DFU) is increasing at an alarming rate and there is an exponential need for diabetic foot management in geriatric population. Around 15% of diabetic patients will develop foot ulcer during their life time. DFU is known to precede amputation in 85% of the cases. It is estimated that every year approximately 45000 lower limb amputations take place in India, and is a matter of concern in geriatric population. Diabetes complication may include nerve damage and reduced blood flow to the feet. Poor blood circulation weakens the bones at the feet. Also due to nerve damage, patient never realize foot fracture due to diabetics. Continued walking on the injured diabetic foot results in severe fracture, dislocation, foot deformation and chronic sores. Diabetic foot ulcer is known to precede amputation in most of the cases. It has been well established that foot pressure off loading is critical for diabetic foot ulcer healing. Therefore, by rehabilitation of diabetic foot, lower limb amputation can be prevented. Currently, bed rest, crutches and orthoses are the widely practiced approaches for diabetic foot ulcer management. However, these devices produced poor results. Also many of these devices led to knee injuries, tissue damage due to hydrostatic compression loading, muscle wasting etc. However, total contact casting method has been found effective in healing foot ulcers. Yet, despite its efficacy difficulty in cast application, active infections in leg, changes in patient leg size in course of time, and cast removal resulted in significantly lower total contact casting usage. Also,

offloading weight from foot will overload another segment of body. Hence for elderly patients with foot ulcer, being on their feet even for one minute is a very painful process. They want to be able to stand without being in pain all the time, which is not at all well addressed by any orthotic offloading device in India as well as abroad.

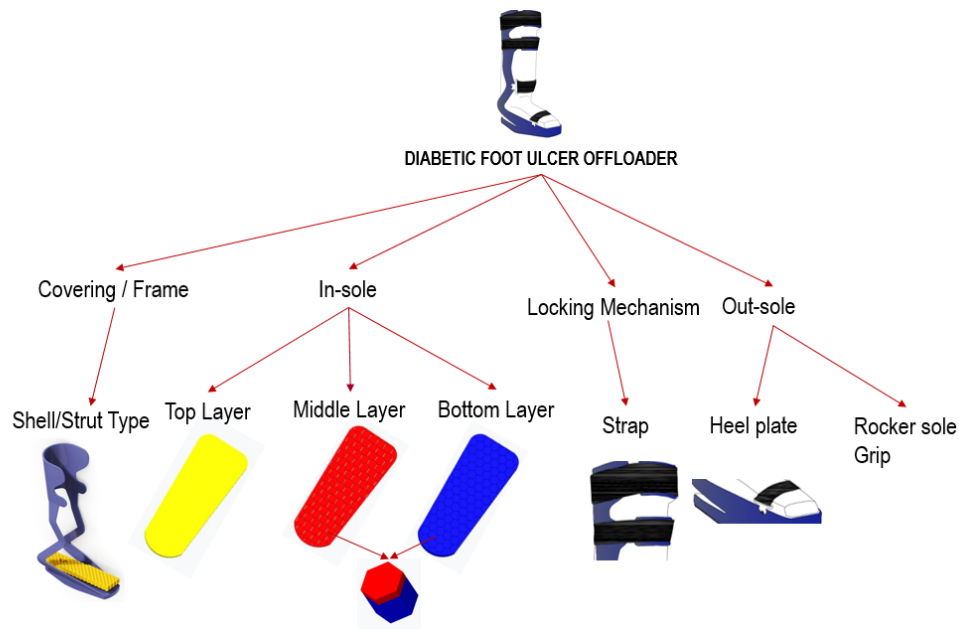

Fig 3.2 System level discretization

In view of the limitations of the existing devices designed for rehabilitation of diabetic foot ulcer, there is a pressing requirement for diabetic foot ulcer offloading devices but without the associated limitations of the current devices. In particular, there is need for an orthotic device which (1) offload plantar pressure from exact locations of diabetic foot ulcer, (2) offloading from one location with no effect or minimum effect on other musculoskeletal segments (3) minimize the occurrence of ulcers at other locations to which the weight is offloaded.

Therefore, it is the principal object of the invention to propose an orthotic device for offloading diabetic foot ulcer. Unlike the existing technology, the device of current

invention simultaneously performs offloading plantar pressure from exact locations of diabetic foot ulcer, with no effect or minimum effect on other musculoskeletal segments thereby minimizing the occurrence of ulcers at other locations to which the weight is offloaded.

Another object of the invention is to propose an orthotic device which consists of an offloading element design, which redistributes the weight of the musculoskeletal segments so that there is minimum or no direct plantar pressure on foot ulcer points or hotspots.

Another object of the invention is to propose an orthotic device which consists of modular cushioning/sweat absorbing/medicated foot insole. Modular units of the foot insole can be selectively removed patient specifically from the insole base. By doing so, the ulcer area will be freely suspended in the air gap with zero plantar pressure. Hence the weight is offloaded by both offloading element and modular foot insole together. A further object of this invention is to propose an orthotic device which consists of adjustable pneumatic pouch pad designed for human calf and shin to reduce the effect of friction and hydrostatic load at the calf region.

The present invention relates to the field of offloading orthotics. More particularly, the invention relates to an orthotic device for treatment and rehabilitation of diabetic ulcer at the plantar surface of the foot. Unlike the existing technology, the device of current invention simultaneously performs offloading plantar pressure from exact locations of diabetic foot ulcer, with no effect or minimum effect on other musculoskeletal segments thereby minimize the occurrence of ulcers at other locations to which the weight is offloaded. The present invention satisfies the main requirement for diabetic foot ulcer treatment and rehabilitation: (1) offloading plantar pressure from exact locations of

diabetic foot ulcer, (2) with no effect or minimum effect on other musculoskeletal segments (3) thereby minimize the occurrence of ulcers at other locations to which the weight is offloaded.

To achieve these goals, the device according to the present invention has:

(1) an offloading element design, which redistributes the weight of the musculoskeletal segments so that there is minimum or no direct plantar pressure on the foot ulcer points.

(2) modular cushioning/sweat absorbing/medicated foot insole which can be selectively removed patient specifically. By doing so, the ulcer area will be freely suspended in the air gap with zero plantar pressure. Hence the weight is offloaded by both offloading element and modular foot insole together.

(3) adjustable pneumatic pouch pad designed for human calf and shin to reduce the effect of friction and hydrostatic load at the calf region.

In the current exertion the main focus is on the development of the sub component of the Diabetic Foot Ulcer Offloading device which is the insole. The insole must be cushioning, sweat absorbing, and should afford removable plugs at ulcer sites. The system consists of 3 layered structure in which the different layers have individual effects on the stress distribution. The hexagonal shape has been implemented for the plug design considering multiple factors including criticality to manufacturing, stress concentration etc.

### **3.2 DEFINITION**

In the Insole design the foremost and first priority is given to plantar pressure redistribution. The insole has stacked multi layers of different material, each layer/material contributing different properties to meet various clinical & functional requirements. At Least one 'removable element' from at least bottom layer (or + intermediate layer) to make an open area and thereby omitting 'wound area' from the role of body weight bearing. Top layer extends over 'Toe edge to heel edge' & 'Medial-Lateral sides'. (Unlike the conventional method- Top layer material removal, this method prevents major draw-backs of its old types, 'Window edema (excess fluid deposit on wounds is prone to microbial growth)', 'Edge pressure(causing reduced blood circulation to wounds)', Scar tissue formation by exudate(crystallization of excess fluid on wounds) and pegs from falling into wound area. At least the top layer is heat formable to match the shape of plantar surface (custom fit) of the foot: Providing maximum area of contact for pressure distribution. Intermediate layer is resilient compressible (Keeping a safe distance in between). Bottom layer is high density resilient material (Perfect cushioning/shock absorber) Mating of Insole design with with heel plate for perfect fit (efficient transfer of contact force prevents from pressure points formation)

In order to study more about different materials and structures of the components a design concept sheet was prepared in which details about the available devices in the market were included in which the different company products across the world were studied and examined.

DESIGN CONCEPT SHEET								
Product: Diabetic Foot Ulcer Off-loader								
As on the inputs gathered from patent review and product brochure.								
Sr.	PARAMETERS	DJO (Aircast) XP DIABETIC WALKER SYSTEM	OSSUR REBOUND DIABETIC WALKER	OPED VACOCAST DIABETIC	BREG CONFORMER DIABETIC WALKER BOOT	DJO MAXTRAX DIABETIC WALKER	OSSUR DH OFFLOADING WALKER	DEFENDER PROTECTIVE BOOT
	System level image							
1	Insole	 Dual-laminate insole designed with the Impax™ grid technology	 Tri-laminate insole with removable shock-absorbing hexagons.  Heat mouldable top layer (Material – Plastazote)	 Vacuum Cushion with adaptable beads.  (No separate insole present)	 Dual density mid-sole foam	 Tri-laminate insole designed with the Impax™ Grid Technology	 Active Offloading Insole  (Conventional top layer removing method)	 Friction reducing, antimicrobial, water-resistant top cover. Durable soft EVA foam. Medium density force reducing foam. High compression resistant open cell urethane foam. (Four Layers)

Fig 3.3 Benchmarking

The design concept sheet consist of the different type of insole that are commercially available in different company products, the materials they use for their products, the no layers in insoles. The techniques used for donning and doffing the insoles etc which were vital for the embodiment design considering different aspects of criticality to manufacturing and criticality to business.

### 3.2.1 Fish Bone Diagram

A visual aid for classifying a problem's possible origins is a fishbone diagram. This technique is used to determine the underlying causes of issues. A fishbone diagram combines the technique of brainstorming with a form of mind map template, and is frequently used for root cause analysis. As a test case technique to ascertain cause and effect, it ought to be effective.

In product development and troubleshooting procedures, a fishbone diagram is helpful because it may be used to centre a discussion on a specific issue. The facilitator works with the group to rank potential causes in order of priority and create a hierarchy once the group has brainstormed every potential source of the issue.

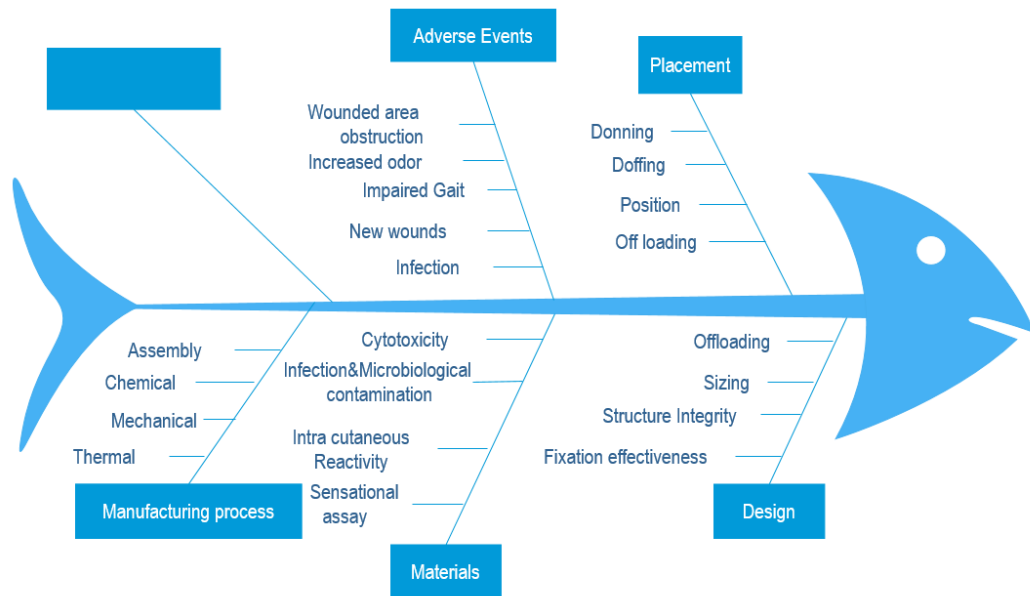

Fig 3.4 Fishbone diagram

In our exertion such risk assessments have been conducted in which the different risk elements were classified in the diagrams including the effects due to certain main components and the sub component effect on the insole. These main issues stated includes Design, Materials, Manufacturing process, Diagnostics, Placements etc.

### 3.2.2 P-Diagram

An optional step in preparing for a System or Subsystem FMEA is a P-Diagram. The team will benefit from seeing these elements graphically when the object being analysed is a complex system with numerous system interactions, operational conditions, and design factors. Although it takes a lot of effort, this stage can be very helpful in understanding and managing the system as well as locating input for the FMEA. If the FMEA team feels that there is sufficient value in visually depicting inputs, ideal response, and noise/control variables, a P-Diagram can also be employed when preparing for a Component FMEA.

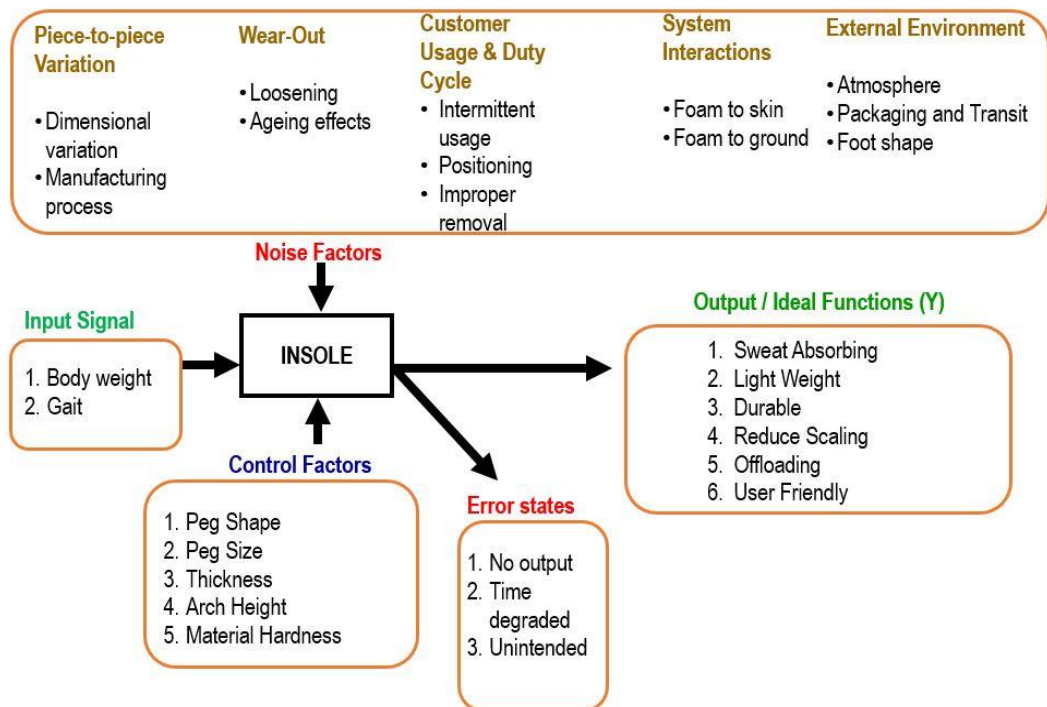

Fig 3.5 P-Diagram

Here in this diagram the input signal indicates what has to given or acting on the system, the output functions are those the system has to provide or give in respect to the input,the

control factors are those that can be optimized and the output functions can adjusted or fine tuned,the noise factors are those factors that affect the design which are not under direct control of the developer and the error states are those inherent losses or undesirable outputs that occurs.

### 3.3 DESIGN AND DEVELOPMENTS

The design space for the insole model was generated through literature, patent review, comparative study etc.Then we minimized and arrived at 4 control factors. The design space contained different control factors such as the Geometry of the pegs, thickness of the top layer, thickness of the middle layer, thickness of the bottom layer.The upper and lower limits of the control factors were developed using the literature survey, patent reviews etc.

Table 3.1 Design Space

Control Factors	UPPER LIMIT	LOWER LIMIT
Edge Length(mm)	10	5
Top Layer Thickness (mm)	6	3
Middle Layer Thickness (mm)	4	2
Bottom Layer Thickness (mm)	13	8

The control factors and ranges of datas were updated into statistical software Minitab. The software was used to perform Full Factorial Design of Experiments. The 2 level full factorial design was used here. When we enter the values into the Minitab, it calculates  $2^k$  DOE's. The value 'k' indicates the total number of control factors. In this exertion the control factors were hence  $2^4 = 16$  DOE's were generated with multiple combinations of the top, middle and bottom layer thicknesses.

Table 3.2 Control Factors

Control factors (X s)			
Edge length (mm)	Top layer thickness (mm)	Middle layer thickness (mm)	Bottom layer thickness (mm)
5	6	4	13
10	3	2	8
10	6	4	8
10	3	4	8
5	6	4	8
5	6	2	8
10	6	2	8
10	3	2	13
5	3	2	13
10	3	4	13
5	3	2	8
10	6	2	13
5	6	2	13
5	3	4	8
5	3	4	13
10	6	4	13

### 3.3.1 Cad Modeling

A 3D cad model of the insole containing the different layers with hexagonal pegs at bottom layers was modeled in Creo. The dimensions which includes the length and width of the insole was kept constant for all DOE's of the insole. The length and width of the insole was considered to be that of a medium foot and the global dimensions corresponding to medium foot was incorporated here.

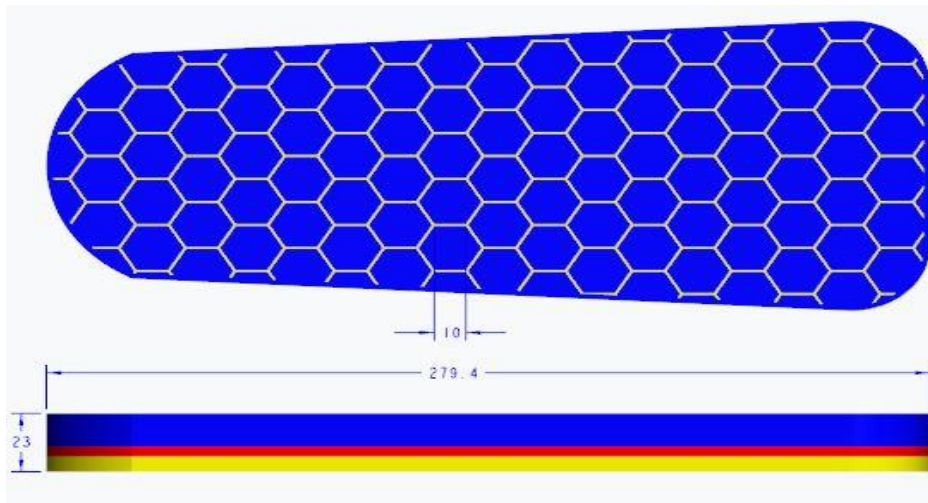
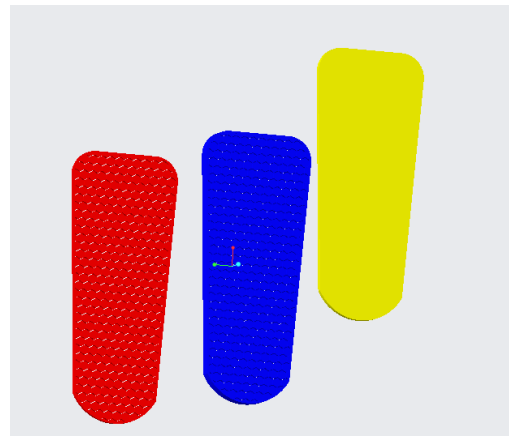
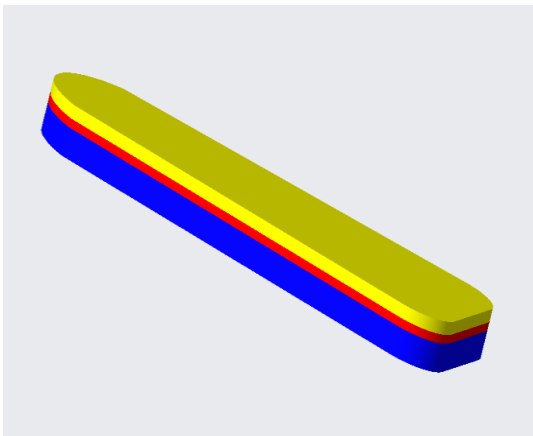

Fig 3.6 Cad Models

### 3.3.2 Pre-Processing

Pre-Processing is the method of dividing the model into finite elements with nodes and elements with different types of elements available in the software and solving the elements according to assigned boundary conditions. The model which has been assembled in Creo 8.0 is transferred as a neutral x\_t Para solid file to Ansys Workbench 18.2.

#### i. Meshing

The mathematical representation of a physical system that includes a part or assembly, material properties, and boundary conditions is called finite element analysis (FEA). It is not always possible to estimate product behavior in the real world using straightforward calculations. By precisely describing physical processes using partial differential equations, a general methodology like FEA offers an easy way to express complicated behaviors. Design engineers and specialists can use FEA now that it has developed and become more accessible.

One of the most crucial processes in carrying out an accurate simulation using FEA is meshing. A mesh is composed of elements that have nodes—coordinate positions in space that might change depending on the element type that symbolise the geometry's shape. Meshing is the act of reducing the amorphous solids into discretisable volumes named as

elements. These elements are then further evaluated one by one at a time using critical mathematical operations. The two primary meshing techniques are as follows. We are referring to 3D models in this context:

Tet, short for tetrahedral element meshing

Mesh of hexahedral elements, or "hex"

In comparison to tet elements, hex or "brick" elements typically produce more accurate results at lower element counts. The optimum option may be tet elements if the geometry is intricate.

Table 3.3 Skewness Table

Value of Skewness	Cell Quality
1	degenerate
0.9 — <1	bad (sliver)
0.75 — 0.9	poor
0.5 — 0.75	fair
0.25 — 0.5	good
>0 — 0.25	excellent
0	equilateral

To check the quality of mesh generated Skewness value and element quality was taken. A high-quality mesh is one of the most critical factors that must be considered to ensure simulation accuracy, and this is why it is very important to check and improve the mesh quality.

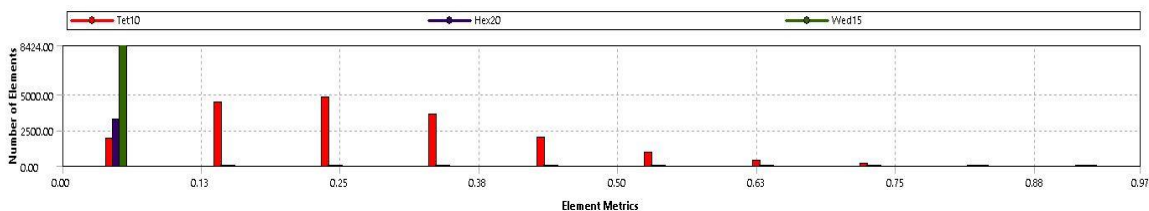
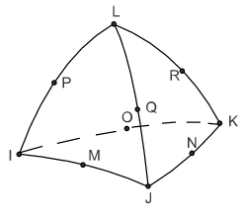

Fig 3.7 Mesh Quality

From the above image it's clear that the average Skewness value and element quality is very good and a limited error percentage was found which may be from the areas where

coarse mesh was given. The mesh had two types of elements 20 node solid and a 10 node tetrahedral elements



SOLID186 Tetrahedral Structural Solid  
Solid

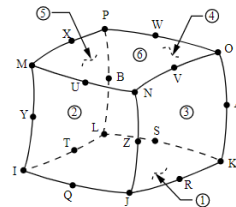

SOLID187 Structural Homogeneous

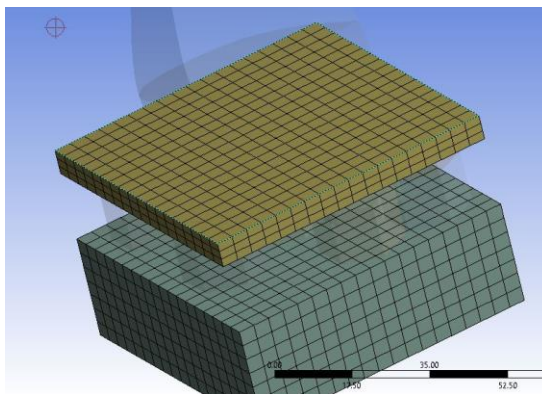
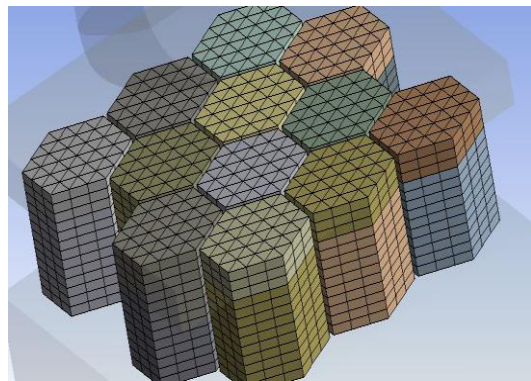
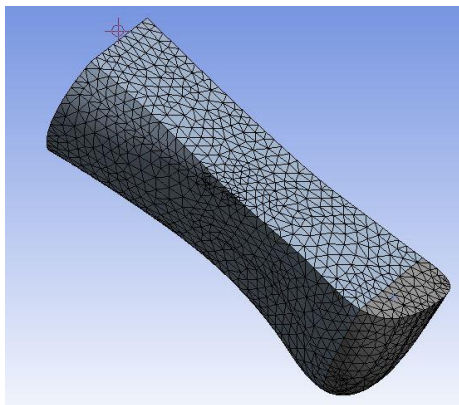

Fig 3.8 Mesh Elements Fig 3.9 Different Mesh Sizes

## ii. Boundary Conditions

The case was set up in the Ansys mechanical pre software. The important details and conditions to be used while doing the setup are explained in this section. The main features of this includes providing the force, the fixed support and restricting the unnecessary motions using constrains.

In this exertion a force of 320 N was applied at the bones towards the ground in order to simulate the reaction. The angle between the heel and insole was set to be 15 degree, which was modeled in creo and the fixed support was given under the layer considered as concrete/ground.

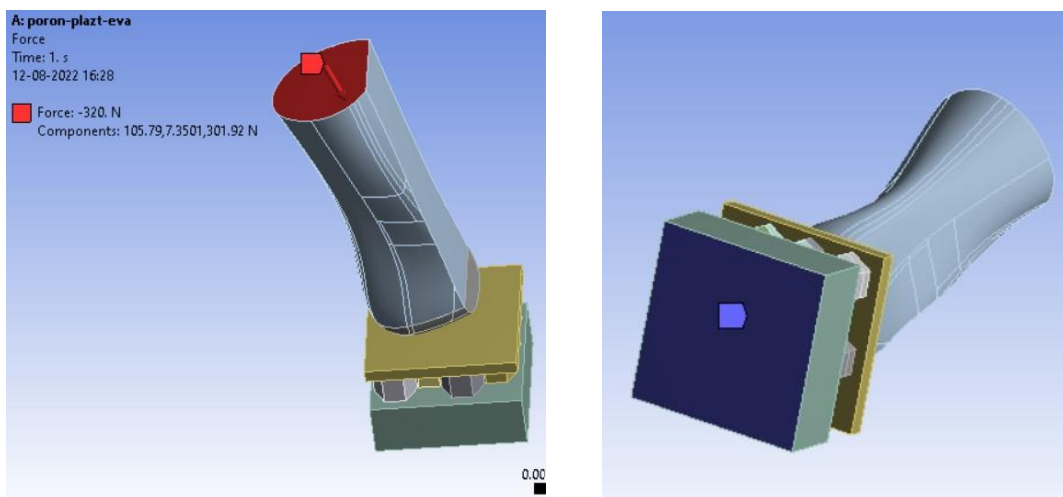

Fig 3.10 Force and Support

In order to constrain the action forces in only one direction, the translational joints from body to ground were also included in which the bone and skin were constrained in all direction other than x direction

## iii. Modeling Contacts

In order to comprehend behavior and load transfer inside an assembly, contacts are often employed to define how pieces interact. Ansys software does not by default presume that a model's bodies are in contact. The user is required to specify the location of contact. Finite element algorithms must be applied in a certain way when dealing with contact difficulties. Contacts is a type of border nonlinearity in which no body can pass through another. Both displacement and contact forces are unknown at the interface when two bodies collide. In order to ascertain where two bodies are in contact, the area of contact, the contact force or pressure at the interface, and whether there is relative motion between the parts following contact, contact analysis must first identify the two bodies in question.

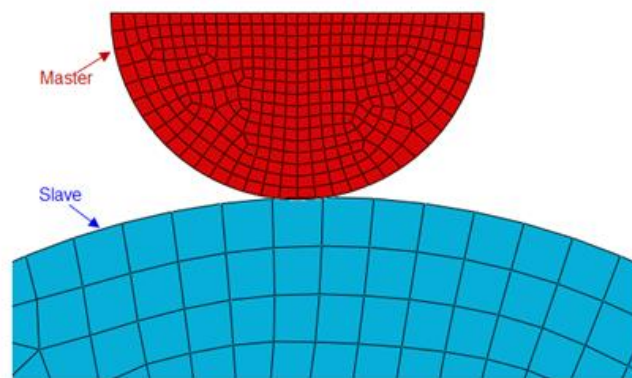

Fig 3.11 Contacts

By taking augmented Lagrange formulation, a normal line drawn from master-slave contact was used to detect contact.

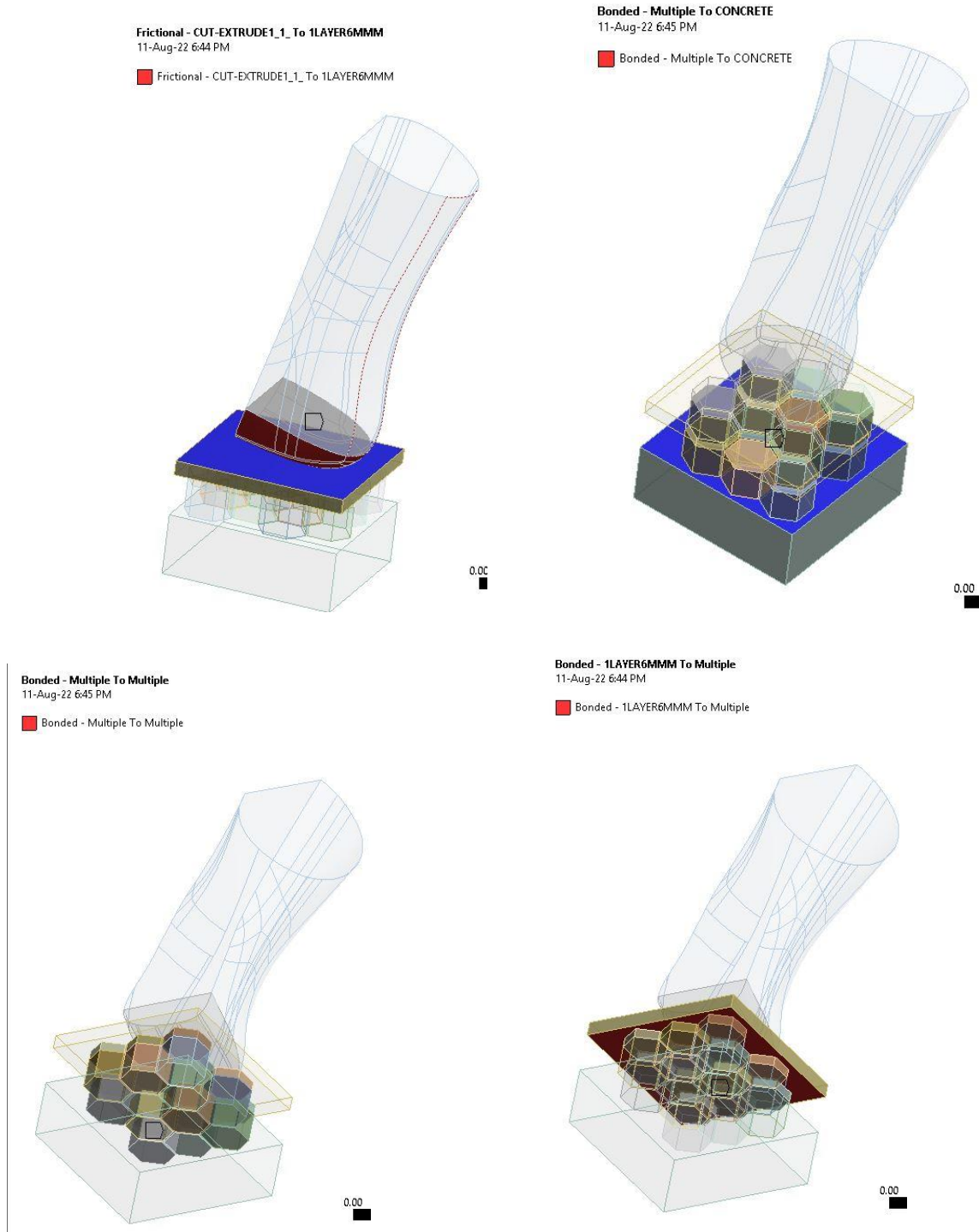

Fig 3.12 Different contacts illustrated

In this case the skin and bone was given bonded contact. The contact between skin and insole was modeled with frictional contact of coefficient 0.2. The contacts between layers

of insole was also given bonded contact as illustrated in figure.

#### iv. Material Selection

This is one of the paramount factors considered for this exertion. The first phase of this section is to fix the materials to different layers. Typically, EVA, Poron, Plastazote are commonly used among commercial products. The ability of the ethylene-vinyl acetate (EVA), Poron, Plastazote, and polyurethane to lower PPP in the plantar region led to the development of these materials. The insole performs a variety of tasks including cushioning, resiliency, and stiffness. Insoles made of EVA have been used in the forefoot, midfoot, and rearfoot plantar regions. Single EVA foam-based material proved excellent for absorbing energy to help the lowering of rearfoot pressure. Furthermore, a foam-based insole made of a combination of EVA and Poron was said to be great for supporting the arch and maximizing insole plugs. By detaching the square plugs from the insole, the PPP in the forefoot area may be adjusted. Furthermore, Plastazote and Polyurethane (PU) were found to be appropriate materials for pressure distribution in a multi-layer shoe's forefoot and rearfoot. In Rogers et al the effect of poron and plastazote on insole was compared and poron was recommended as it has high elastic memory property compared with plastazote hence resist deformation from repeated loading and maintain peak pressure reduction throughout. So in our design three materials was finalized from literatures and market study:

- EVA (Nora AL)
- Open Cell Polyurethane (Poron)
- Closed Cell Polyethylene (Plastazote)

After the materials are selected, each material has to be assigned to different layers

according to their applications and properties. The middle layer and bottom layer was given Closed Cell Polyethylene (Plastazote) and EVA (Nora AL) respectively from multiple studies and for the top layer to be finalized the three combination with these different materials at top layers and other layers were fixed was simulated with same setups and boundary conditions and arrived at Open Cell Polyurethane (Poron) was best suited for top layer, since the skin stresses was minimum at “Poron-Plastazote-EVA” combination than all other combinations. The results are further discussed in next section.

Table 3.4 Materials of Different Layers

LAYERS	MATERIAL	JUSTIFICATION
TOP LAYER	PORON(Polyurethane)	The material should have proper cushioning effect  Proper distribution of stresses across layers
MIDDLE LAYER	PLASTAZOTE(Polyethylene)	This material has poor elastic memory property hence unable to use as top layer  It redistributes plantar pressure to wide areas
BOTTOM LAYER	NORA AL(EVA)	High abrasion resistance and rigid  Existence is of this at middle layer is not suitable.

## v. Material Properties

The material properties assigning plays a very important role in the simulation, here we used stress-strain graph obtained from different test methods of our choice materials from literatures for assigning the properties. The curve fitting was used for certain materials. The insole materials and skin showed non linear behavior. The 3<sup>rd</sup> order Ogden hyper elastic material model was used for insole materials.

$$W(\lambda_1, \lambda_2, \lambda_3) = \sum_{p=1}^N \frac{\mu_p}{\alpha_p} (\lambda_1^{\alpha_p} + \lambda_2^{\alpha_p} + \lambda_3^{\alpha_p} - 3)$$

Table 3.5 Skin Material Properties

Material	C10 (Pa)	C01(Pa)	C20(Pa)	C11(Pa)	C02(Pa)	D1 (Pa <sup>-1</sup> )	D2(Pa <sup>-1</sup> )
SKIN	85550	-58400	38920	- 23100	8484	. 4370E-05	. 6811E-06

Polynomial 2<sup>nd</sup> order hyper elastic material model was used for insole materials.

$$W = \sum_{i,j=0}^n C_{ij} (I_1 - 3)^i (I_2 - 3)^j$$

Bone was modeled as isotropic elastic having an elastic modulus of 7300 MPa and Poisson ratio of 0.3. The plantar skin values were taken according to literature; the values are given in table below.

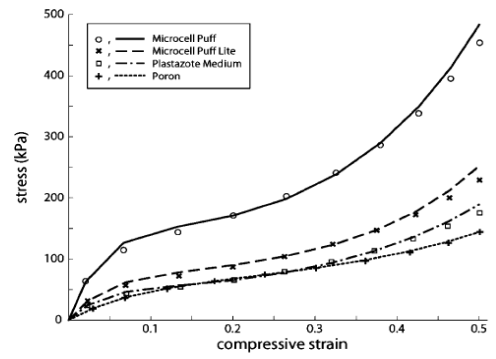
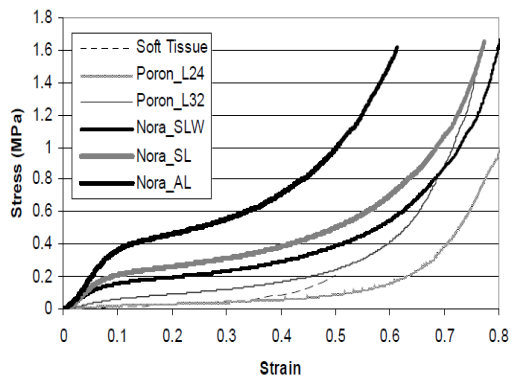

Fig 3.13 Stress – Strain Graph of Materials

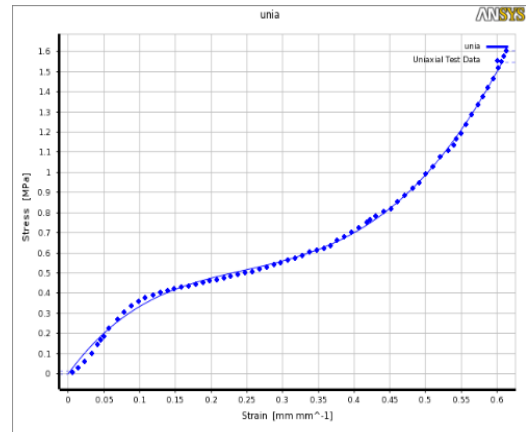
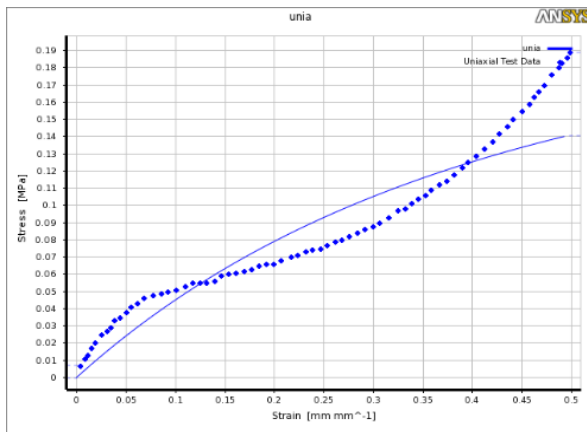

Fig 3.14 Curve Fitting Graph Using Ansys

Table 3.6 Material Properties of Insole Materials

Material	D1 ( $MPa^{-1}$ )	D2 ( $MPa^{-1}$ )	D3 ( $MPa^{-1}$ )	A1	A2	A3	MU1 (MPa)	MU2 (MPa)	MU3 (MPa)
EVA	0	0	0	2.285	4.180	0.664	- 24.902	4.083	64.87 6
PORON	0	0	0	9.346	13.41 8	5.382	-0.028	0.003	0.109
PLASTAZOTE	0	0	0	0.036	0.036	0.036	3.158	3.158	3.158

### 3.4 FINITE ELEMENTAL ANALYSIS

Steps are crucial to static analysis in ANSYS. It is crucial to modify an analysis's processes in accordance with a system's loads, circumstances, and response frequencies. By turning loads and conditions on and off in time increments, we can modify how they are applied. In ANSYS, this provides very good control to get the precise physical phenomenon. The following list includes all step controls for this analysis:

**Number of Steps:** The first selection under "step controls" is this. To specify how many steps will be taken throughout the analysis, we can input a value.

**Current Step Number:** In ANSYS, we can discretely alter each step. We can modify the step, for instance, by entering a value in the field labelled "Current Step Number." This choice is followed by step controls that are specific to the current step.

**Step End Time:** This indicates the moment at which the selected step in "Current Step Number" will come to an end.

**Auto Time Stepping:** In ANSYS, this crucial setting can be turned on or off. Because of

the nonlinear load on this system, using the auto time stepping option can be quite beneficial. Three values that need to be adjusted for the current step number will show up when the auto time stepping option has been enabled.

- **First Time Step:** This refers to the beginning of the chosen step. The loads or conditions will be applied when the step begins and solved at the conclusion of this first-time step. The following sub-step will make use of these sub-solutions.
- **Maximum Time Step:** Automatic time-stepping divides the chosen step into the "Current Step Number." This is the largest time increment that auto time stepping will produce inside a step. Inside of it, a value can be defined.
- **Minimum Time Step:** This is the smallest time step inside the currently selected step in the field "Current Step Number."

The solver system was given program controlled. Large deflection was turned 'on' because it was mandatory to turn 'on' large deflection because joint support was assigned. Understanding the solution output is key to troubleshooting convergence problems.

The solution was seen converging within the first iteration indicating that the output will most probably converge. During analysis force convergence values were steadily decreasing with little or no oscillation. Max DOF values were small and steadily decreasing. This indicates that the part has not broken free and flown off onto space further we can also confirm that the result will converge and display accurate solution.

### **3.5 POST PROCESSING**

Three steps make up the FEA validation process: accuracy checks, mathematical validity tests, and correlation. Early in the FEA development process, the first two processes are completed, and the third step concentrates on comparison with experimental data. An

enormous amount of raw data is often the result of a solver. Without the data sorting and graphical representation known as post-processing, this amount of raw data would typically be challenging and time-consuming to analyze.

The distribution of stresses, strains, deformations, temperatures, and other model components are displayed graphically via post-processing. The key to interpreting these post-processed results is to identify potential problem areas (weak areas in a model), material waste areas (areas of the model bearing little to no load), or valuable information on other model performance characteristics (thermal, modal) that otherwise would not be known until a physical model were built and tested (a "prototype").

The most critical thinking is required during the post-processing stage of FEA, when the user evaluates the outcomes (the numbers vs. color contours, movements, etc.) and contrasts them with potential outcomes. It must be emphasized again and again that it is up to the user to decide whether the results make sense and whether they can be justified using engineering "common sense." Before one can fully believe the results if the results are not what was anticipated, one must look for an explanation. In current project the stress , strain and deformations results were analyzed which shown in the table.

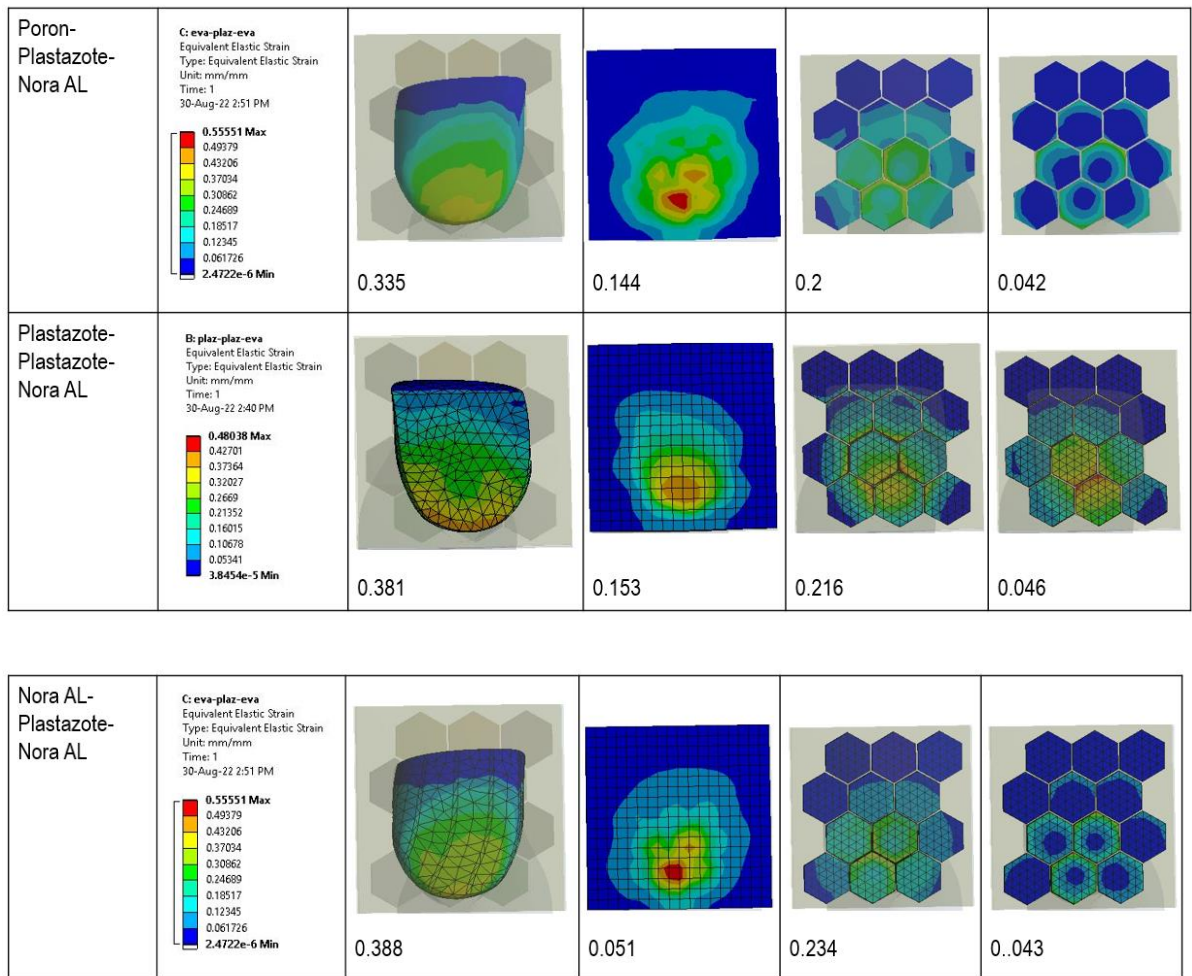

Fig 3.15 Stress FEA results

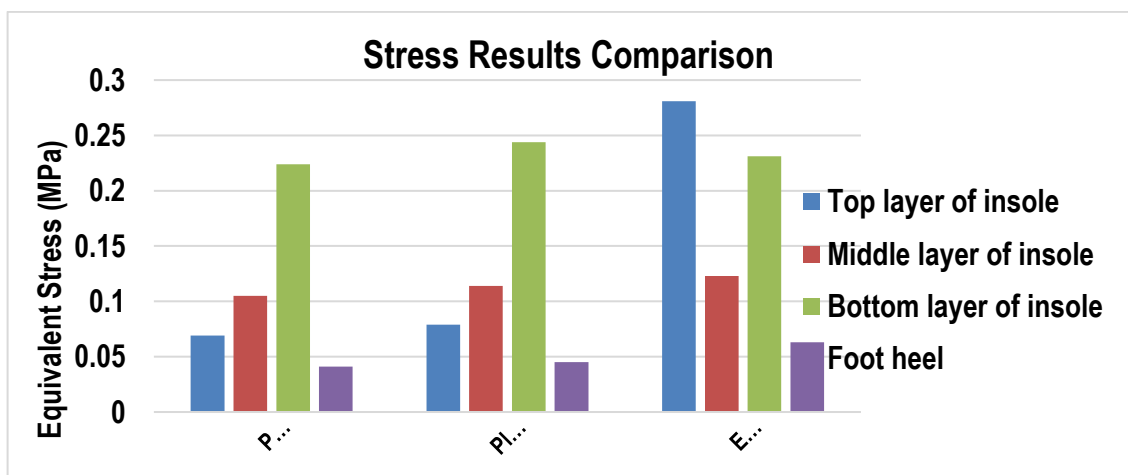

Fig 3.16 Stress comparison

The stress results were tabulated for the material selection process and from the results

we came to the conclusion that the von-Mises stress at heel is found to be minimum for the combination of “Poron-Plastazote-EVA”.Hence “Poron-Plastazote-EVA” combination is selected for insole construction.The stress reduction in “ Poron-Plastazote-EVA” was in range with values of a journal paper.Further more the stress reduction compared to barefoot was found out.There was approximate 50% reduction in stress we predicted when “Poron-Plastazote-EVA” insole combination was used. The total percentage of reduction was in range with the values from a journal paper.

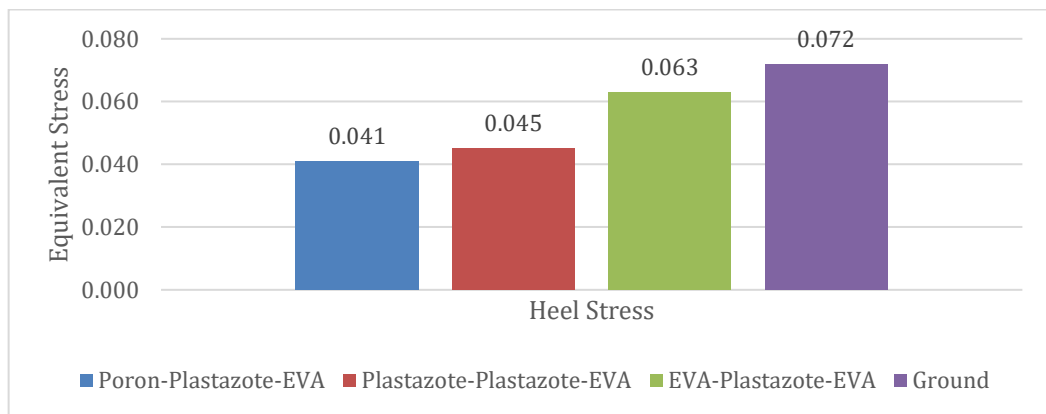

Fig 3.17 Heel Stresses

## CHAPTER 4

### RESULTS

The stress, strain and deformations results were analyzed from the FEA simulations and tabulated.

Table 4.1 Control Factors Results

Control factors (X s)				Output (Ys)		
Edge length (mm)	Top layer thickness (mm)	Middle layer thickness (mm)	Bottom layer thickness (mm)	Y1(Stress MPa)	Y2(Strain)	Y3(Deformation)
5	6	4	13	0.245	0.239	1.428
10	3	2	8	0.236	0.229	0.701
10	6	4	8	0.208	0.182	1.126
10	3	4	8	0.294	0.235	1.072
5	6	4	8	0.273	0.244	1.29
5	6	2	8	0.253	0.274	1.045
10	6	2	8	0.222	0.22	1.015
10	3	2	13	0.176	0.19	0.643
5	3	2	13	0.283	0.306	0.962
10	3	4	13	0.214	0.197	0.957
5	3	2	8	0.295	0.328	0.815
10	6	2	13	0.191	0.187	0.956
5	6	2	13	0.275	0.277	1.287
5	3	4	8	0.37	0.333	1.223
5	3	4	13	0.307	0.317	1.348
10	6	4	13	0.2	0.187	1.243

The different control factors create 16 DOE's and after further simulation of the DOE's the different outputs represented as Y's stress, strain and deformations were note down

and this results were given to the Minitab were Full Factorial optimization was performed for each DOE's and the results were analyzed.

#### 4.1 STRESS

The model summary equation from Minitab is given below which show that how well the model fits your data and predict how good the statistical regression can be.

S	R-sq	R-sq(adj)	R-sq(pred)
0.0086494	99.24%	97.14%	87.81%

S can be used to evaluate how effectively the model captures the response. To compare the fit of models without constants, use S rather than the  $R^2$  statistics measures how far the data values deviate from the fitted values and is expressed in the units of the response variable. The better the model describes the reaction, the lower the value of S. A low S number, however, does not necessarily mean that the model fulfils the model assumptions. To confirm the assumptions, you should examine the residual plots. The better the model fits your data, the greater the  $R^2$  number.  $R^2$  always ranges from 0% to 100%.  $R^2$  always rises as the number of predictors in a model grows. For instance, the top five models will always have an  $R^2$  that is at least as high as the top four models. The best usage of  $R^2$  is therefore when comparing models of the same size. When comparing models with various numbers of predictors, use adjusted  $R^2$ . Even when there is no actual improvement to the model,  $R^2$  always rises when a predictor is added. The modified  $R^2$  value takes into account the number of predictors in the model to aid in model selection. To evaluate how effectively your model foresees the outcome given fresh observations, use predicted  $R^2$ . Better predictions can be made by models with higher

anticipated  $R^2$  values.

If the predicted  $R^2$  is significantly lower than the actual  $R^2$ , the model may be over-fit. When you include words for effects that are not significant in the population, the model becomes over-fit. Predictions regarding the population may not be useful since the model becomes customized to the sample data. Because predicted  $R^2$  is determined using observations that are not included in the model calculation, it can be more helpful for comparing models than adjusted  $R^2$ . In these results, the model explains 99.24% of the variation in light output. For these data, the  $R^2$  value indicates the model provides a good fit to the data. If additional models are fit with different predictors, use the adjusted  $R^2$  values and the predicted  $R^2$  values to compare how well the models fit the data.

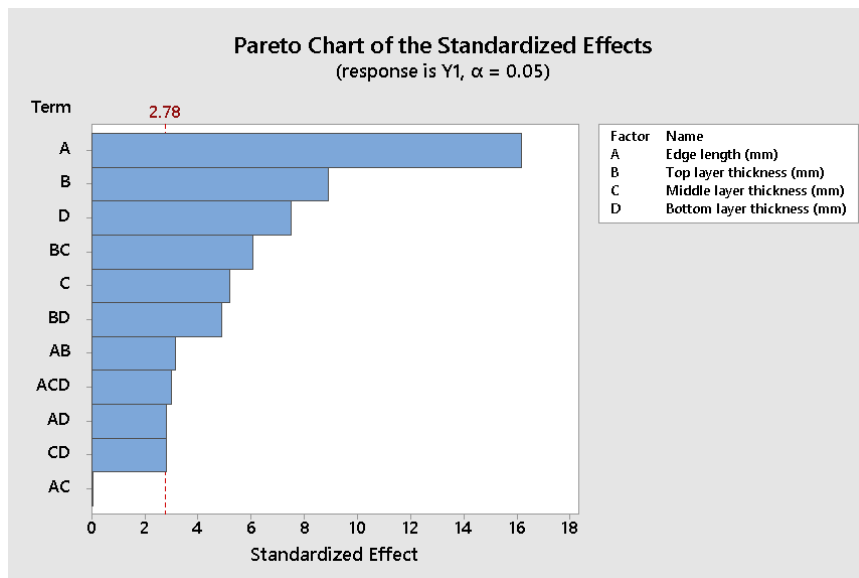

Fig 4.1 Pareto Chart of Stress

The Pareto chart indicates the importance and ranking of each term in the regression in this chart, the terms A, B, C, BC, C, BD, AB, ACD were crossing the reference line which indicates these are significant at 0.05 level in current model.

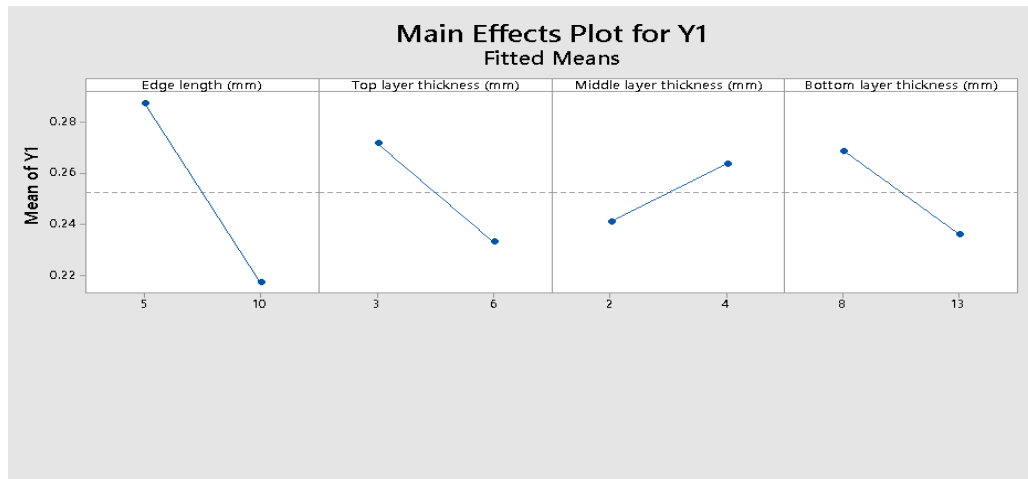

Fig 4.2 Main effects plot of Stress

The means within a category variable are shown in the main effects graphic for each group. The means for each value of a categorical variable are shown by Minitab to construct the main effects plot. Each variable's points are connected by a line. Check the line to see if a main effect exists for a category variable. The overall mean is where Minitab also drew a reference line. According to this interpretation, the line connecting the means:

No main effect is seen when the line is horizontal (parallel to the x-axis). Across all factor values, the response mean is the same.

A main effect is observed when the line is not horizontal. Across all factor levels, the response mean is not the same.

Here in this model the effect of edge length indicates that decrease in the value results in increased stresses. The effect of top layer thickness indicates that decrease in the value results in increased stresses. The effect of middle layer thickness indicates that increase in the value results in increased stresses. The effect of bottom layer thickness indicates that decrease in the value results in increased stresses.

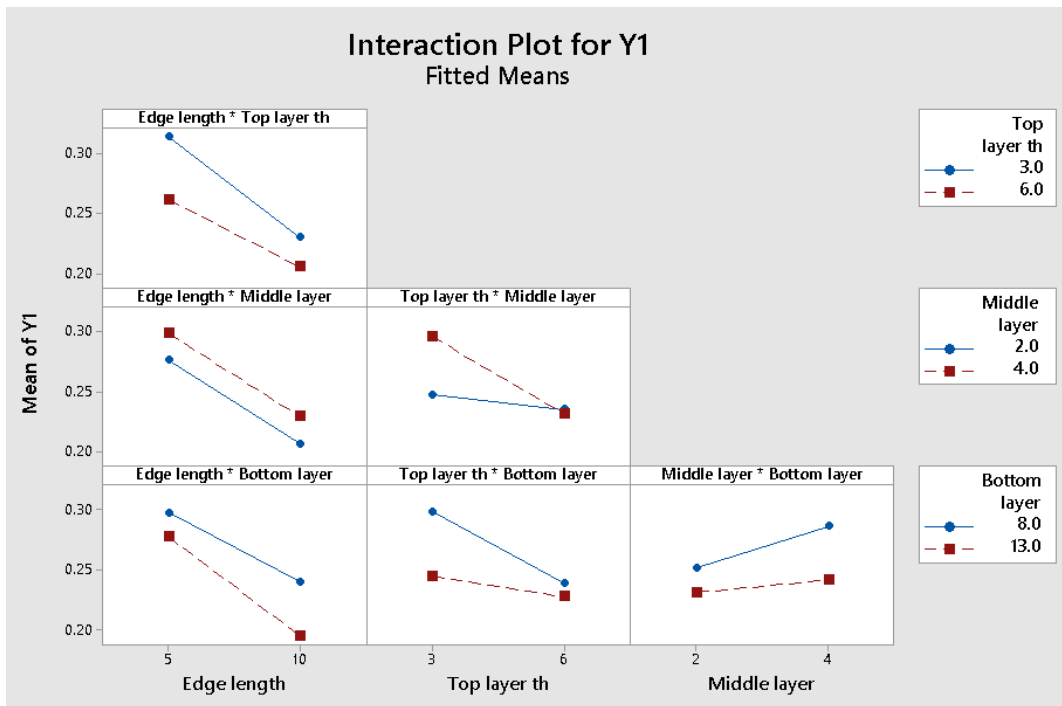

Fig 4.3 Interaction Plot of Stress

The figure shows the interaction between control factors and their effect on the stress, for edge length the increase in edge length will introduce the effect of top layer thickness in reduction of stresses and with decrease in edge length there comes the bottom layer thickness which influences in the increased stress and middle layer has no effect on the edge length interaction. Now coming on to top layer thickness the increase in the thickness leads to the effect of bottom and middle layers for the stress reduction. Finally with decrease in thickness of middle layer bottom layer interaction becomes a factor for stress reduction.

$$\begin{aligned}
 Y1 = & 0.129 + 0.0207 \text{ Edge length (mm)} - 0.03008 \text{ Top layer thickness (mm)} \\
 & + 0.1579 \text{ Middle layer thickness (mm)} + 0.01885 \text{ Bottom layer thickness (mm)} \\
 & + 0.001833 \text{ Edge length (mm)} * \text{Top layer thickness (mm)} \\
 & - 0.01087 \text{ Edge length (mm)} * \text{Middle layer thickness (mm)} \\
 & - 0.00410 \text{ Edge length (mm)} * \text{Bottom layer thickness (mm)}
 \end{aligned}$$



usage of  $R^2$  is therefore when comparing models of the same size. When comparing models with various numbers of predictors, use adjusted  $R^2$ . Even when there is no actual improvement to the model,  $R^2$  always rises when a predictor is added. The modified  $R^2$  value takes into account the number of predictors in the model to aid in model selection. To evaluate how effectively your model foresees the outcome given fresh observations, use predicted  $R^2$ . Better predictions can be made by models with higher anticipated  $R^2$  values.

If the predicted  $R^2$  is significantly lower than the actual  $R^2$ , the model may be over-fit. When you include words for effects that are not significant in the population, the model becomes over-fit. Predictions regarding the population may not be useful since the model becomes customized to the sample data. Because predicted  $R^2$  is determined using observations that are not included in the model calculation, it can be more helpful for comparing models than adjusted  $R^2$ . In these results, the model explains 98.80% of the variation in light output. For these data, the  $R^2$  value indicates the model provides a good fit to the data. If additional models are fit with different predictors, use the adjusted  $R^2$  values and the predicted  $R^2$  values to compare how well the models fit the data.

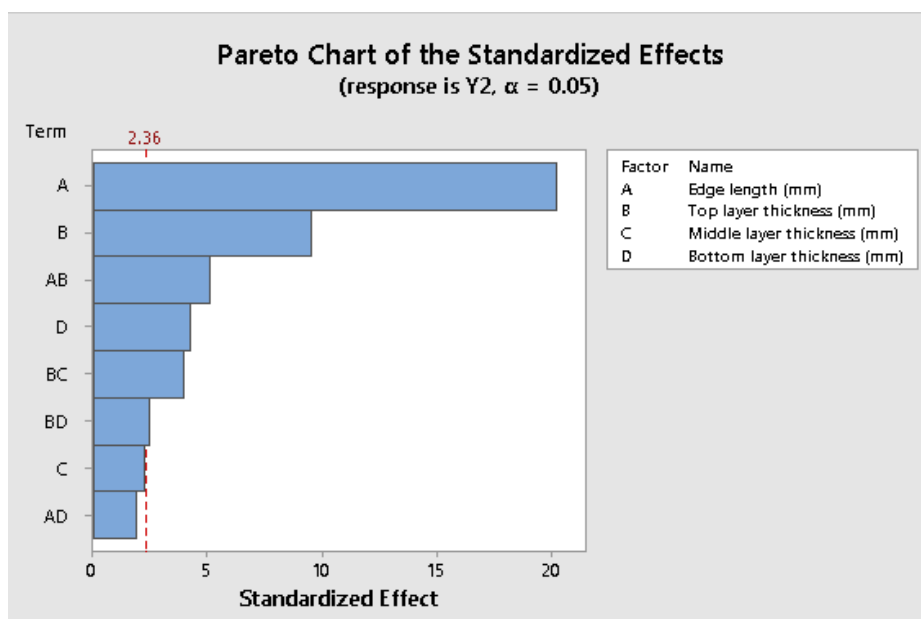

Fig 4.4 Pareto Chart of Strain

The pareto chart indicates the importance and ranking of each term in the regression in this chart, the terms A, B, AB, D, BC, BD were crossing the reference line which indicates these are significant at 0.05 level in current model.

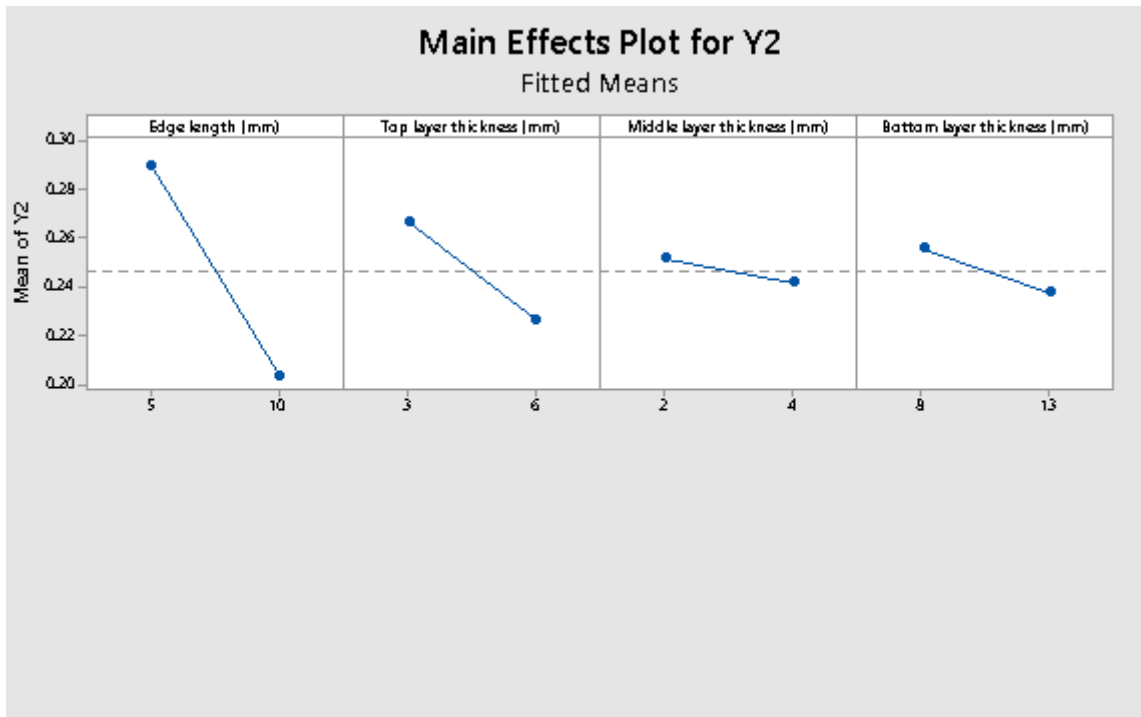

Fig 4.5 Main effects plot of Strain

The means within a category variable are shown in the main effects graphic for each group. The means for each value of a categorical variable are shown by Minitab to construct the main effects plot. Each variable's points are connected by a line. Check the line to see if a main effect exists for a category variable. The overall mean is where Minitab also drew a reference line. According to this interpretation, the line connecting the means:

No main effect is seen when the line is horizontal (parallel to the x-axis). Across all factor values, the response mean is the same.

A main effect is observed when the line is not horizontal. Across all factor levels, the response mean is not the same.

Here in this model the effect of edge length indicates that decrease in the value results in increased strain results. The effect of top layer thickness indicates that decrease in the value results in increased strain. The effect of middle layer thickness indicates that decrease in the value results in increased strain. The effect of bottom layer thickness indicates that decrease in the value results in increased strain.

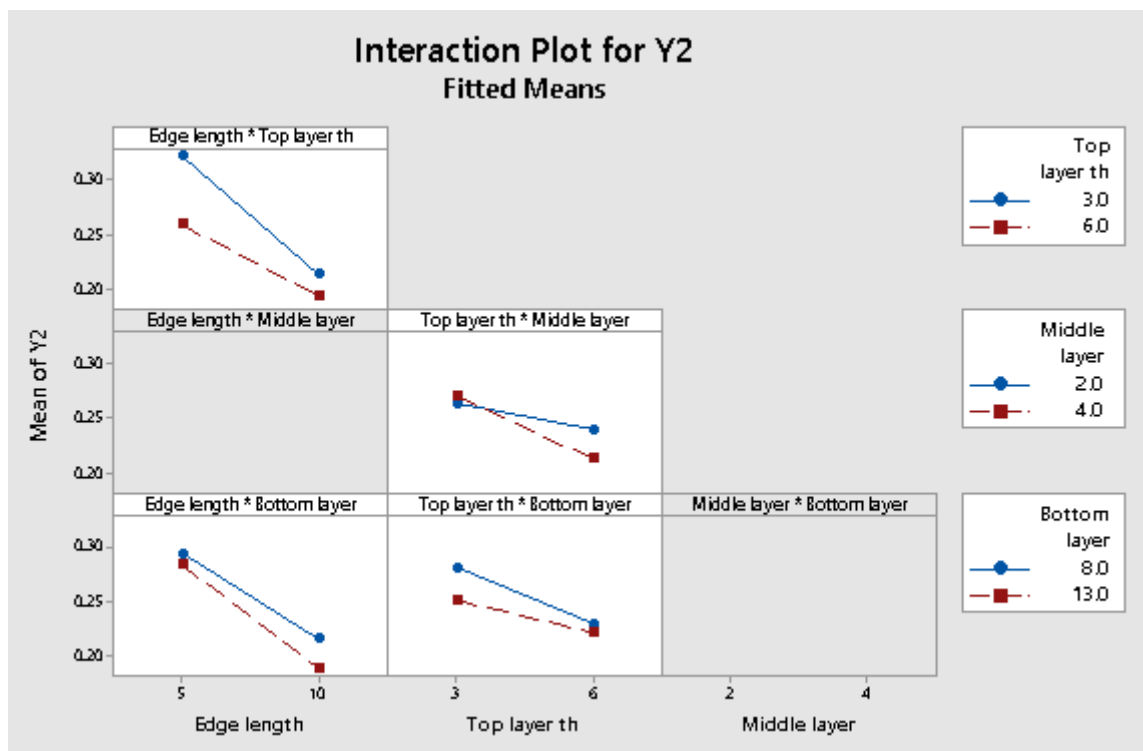

Fig 4.6 Interaction Plot of Strain

The figure shows the interaction between control factors and their effect on the strain, for edge length the increase in edge length will introduce the effect of top layer thickness in reduction of strain and with decrease in edge length there comes the bottom layer

thickness which influences in the increased strain. Now coming on to top layer thickness the increase in the thickness leads to the interaction of bottom layer in the strain reduction. The decrease in thickness will create an interaction with middle for increased strain.

$$\begin{aligned}
 Y_2 = & 0.5278 - 0.02357 \text{ Edge length (mm)} - 0.03342 \text{ Top layer thickness (mm)} \\
 & + 0.02050 \text{ Middle layer thickness (mm)} - 0.00512 \text{ Bottom layer thickness (mm)} \\
 & + 0.002917 \text{ Edge length (mm)} * \text{Top layer thickness (mm)} \\
 & - 0.000650 \text{ Edge length (mm)} * \text{Bottom layer thickness (mm)} \\
 & - 0.00563 \text{ Top layer thickness (mm)} * \text{Middle layer thickness (mm)} \\
 & + 0.001417 \text{ Top layer thickness (mm)} * \text{Bottom layer thickness (mm)}
 \end{aligned}$$

To explain the connection between the response and the model variables, use the regression equation. The regression equation is the regression model's algebraic representation.

### 4.3 DEFORMATION

The model summary equation from Minitab is given below which show that how well the model fits your data and predict how good the statistical regression can be.

S	R-sq	R-sq(adj)	R-sq(pred)
0.0477219	97.67%	95.63%	90.68%

S can be used to evaluate how effectively the model captures the response. To compare the fit of models without constants, use S rather than the  $R^2$  statistics measures how far the data values deviate from the fitted values and is expressed in the units of the response variable. The better the model describes the reaction, the lower the value of S. A low S number, however, does not necessarily mean that the model fulfils the model

assumptions. To confirm the assumptions, you should examine the residual plots. The better the model fits your data, the greater the  $R^2$  number.  $R^2$  always ranges from 0% to 100%.  $R^2$  always rises as the number of predictors in a model grows. For instance, the top five models will always have an  $R^2$  that is at least as high as the top four models. The best usage of  $R^2$  is therefore when comparing models of the same size. When comparing models with various numbers of predictors, use adjusted  $R^2$ . Even when there is no actual improvement to the model,  $R^2$  always rises when a predictor is added. The modified  $R^2$  value takes into account the number of predictors in the model to aid in model selection. If the predicted  $R^2$  is significantly lower than the actual  $R^2$ , the model may be over-fit. When you include words for effects that are not significant in the population, the model becomes over-fit. Predictions regarding the population may not be useful since the model becomes customized to the sample data. Because predicted  $R^2$  is determined using observations that are not included in the model calculation, it can be more helpful for comparing models than adjusted  $R^2$ . In these results, the model explains 97.67% of the variation in light output. For these data, the  $R^2$  value indicates the model provides a good fit to the data. If additional models are fit with different predictors, use the adjusted  $R^2$  values and the predicted  $R^2$  values to compare how well the models fit the data.

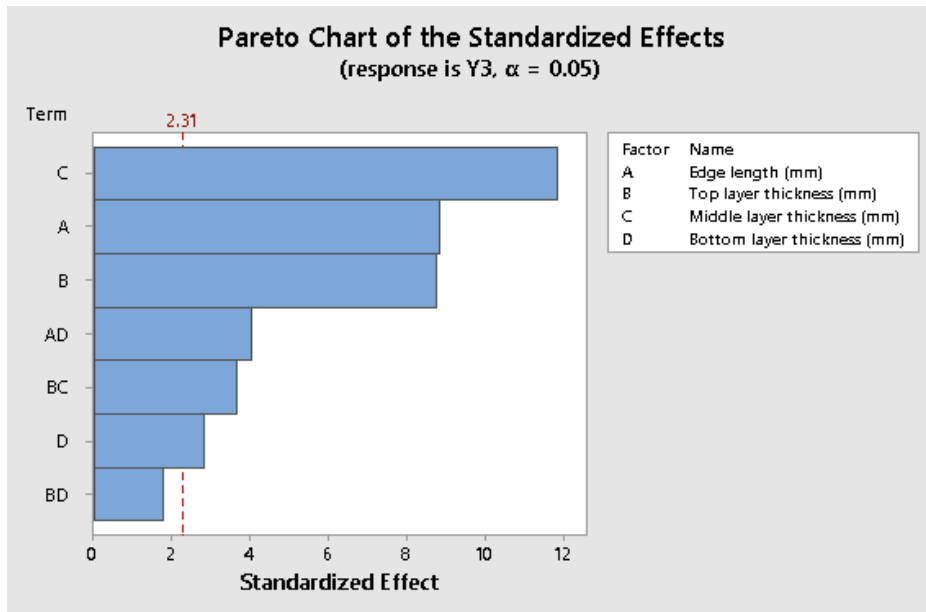

Fig 4.7 Pareto Chart of Deformation

The pareto chart indicates the importance and ranking of each term in the regression in this chart, the terms C, A, B, AD, BC, D, BD were crossing the reference line which indicates these are significant at 0.05 level in current model.

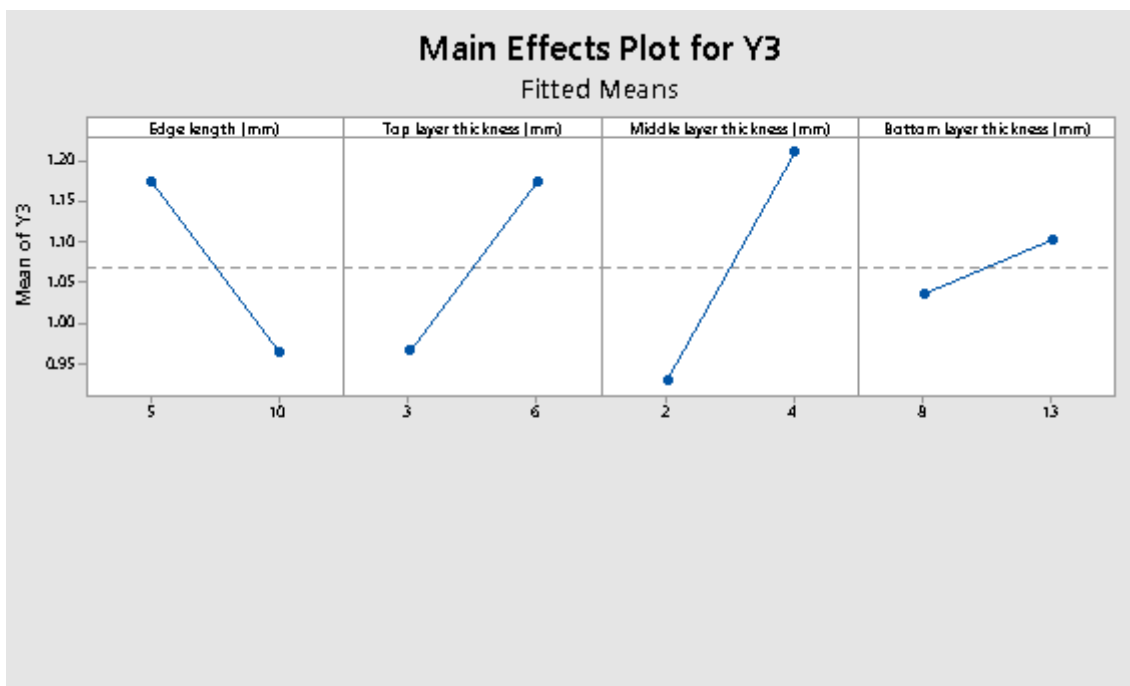

Fig 4.8 Main effects plot of Deformation

The means within a category variable are shown in the main effects graphic for each group. The means for each value of a categorical variable are shown by Minitab to construct the main effects plot. Each variable's points are connected by a line. Check the line to see if a main effect exists for a category variable. The overall mean is where Minitab also drew a reference line. According to this interpretation, the line connecting the means: No main effect is seen when the line is horizontal (parallel to the x-axis). Across all factor values, the response mean is the same. A main effect is observed when the line is not horizontal. Across all factor levels, the response mean is not the same. Here in this model the effect of edge length indicates that decrease in the value results in increased deformations. The effect of top layer thickness indicates that decrease in the value results in reduced deformation. The effect of middle layer thickness indicates that decrease in the value results in reduced deformation. The effect of bottom layer thickness indicates that decrease in the value results in reduced deformations.



Fig 4.9 Interaction Plot of Deformation

The figure shows the interaction between control factors and their effect on the deformation, for edge length the increase in edge length will introduce the effect of the bottom layer thickness which influences in the reduced deformations. Now coming on to top layer thickness the increase in the thickness leads to the interaction of middle layer in the increase of deformation. The decrease in thickness will create an interaction with bottom layer for increased reduced deformations.

$$\begin{aligned}
 Y3 = & -0.221 + 0.0384 \text{ Edge length (mm)} + 0.0971 \text{ Top layer thickness (mm)} \\
 & + 0.2718 \text{ Middle layer thickness (mm)} + 0.0455 \text{ Bottom layer thickness (mm)} \\
 & - 0.00767 \text{ Edge length (mm)} * \text{Bottom layer thickness (mm)} \\
 & - 0.02896 \text{ Top layer thickness (mm)} * \text{Middle layer thickness (mm)} \\
 & + 0.00565 \text{ Top layer thickness (mm)} * \text{Bottom layer thickness (mm)}
 \end{aligned}$$

To explain the connection between the response and the model variables, use the regression equation. The regression equation is the regression model's algebraic representation.

## CHAPTER 5

### CONCLUSION

From the above exertion we can come to the conclusion that the Poron-Plastazote- Eva can be the best suited option for multiple layered insole with removable pegs, this combination has the best result for the skin stresses compared with other combination and also has different layers has significant application on their layered positions. Furthermore, after the optimization using the four control factors Edge Length, Top Layer thickness, Middle Layer thickness, and Bottom Layer thickness in Minitab using 2 level full factorial DOE, analyzing 16 Doe's. The 16 models were simulated and the corresponding out in term of Y's were generated and these Y1,Y2,Y3 were given into the statistical software and the different plots were generated for different Y's in which the ranking of different control factors and their impact on the outputs. The interaction multiple control factors were found out. The regression equation provides the issole stresses for different combinations and these results was again verified with the simulations. The regression equation was developed in which the statistical based model provided a comprehensive and knowledge based criteria for developing the guidelines or insoles for diabetic foot off loaders from different variations or custom based applications. This helped the manufactures and clinicians to prescribe and fabricate optimized orthosis to improve the performances.

## REFERENCES

1. Shaulian H, Gefen A, Solomonow-Avnon D, Wolf A. Finite element-based method for determining an optimal offloading design for treating and preventing heel ulcers. *Computers in Biology and Medicine*. 2021 Apr 1;131:104261.
2. Ghassemi A, Mossayebi AR, Jamshidi N, Naemi R, Karimi MT. Manufacturing and finite element assessment of a novel pressure reducing insole for Diabetic Neuropathic patients. *Australasian physical & engineering sciences in medicine*. 2015 Mar;38(1):63-70.
3. Cheung JT, Zhang M. Parametric design of pressure-relieving foot orthosis using statistics-based finite element method. *Medical engineering & physics*. 2008 Apr 1;30(3):269-77.
4. Rogers KO, Otter SJ, Birch I. The effect of PORON® and Plastazote® insoles on forefoot plantar pressures. *British Journal of Podiatry*. 2006;9(4):111.
5. Lemmon D, Shiang TY, Hashmi A, Ulbrecht JS, Cavanagh PR. The effect of insoles in therapeutic footwear—a finite element approach. *Journal of biomechanics*. 1997 Jun 1;30(6):615-20.
6. Lin TL, Sheen HM, Chung CT, Yang SW, Lin SY, Luo HJ, Chen CY, Chan I, Shih HS, Sheu WH. The effect of removing plugs and adding arch support to foam based insoles on plantar pressures in people with diabetic peripheral neuropathy. *Journal of foot and ankle research*. 2013 Dec;6(1):1-9.
7. Haris F, Liau BY, Jan YK, Akbari VB, Primanda Y, Lin KH, Lung CW. A Review of the Plantar Pressure Distribution Effects from Insole Materials and at Different Walking Speeds. *Applied Sciences*. 2021 Dec 13;11(24):11851.
8. Subhash NN, Mehra N, Choudhary A, Baby CJ, Aravind AU, Benny P,

- Muraleedharan CV. Structural Performance Assessment of FUPRO Grace Foot. *Trends in Biomaterials & Artificial Organs*. 2022 May 17;36(2):94-101.
9. Erdemir A, Saucerman JJ, Lemmon D, Loppnow B, Turso B, Ulbrecht JS, Cavanagh PR. Local plantar pressure relief in therapeutic footwear: design guidelines from finite element models. *Journal of biomechanics*. 2005 Sep 1;38(9):1798-806.
  10. Saeedi P, Petersohn I, Salpea P, Malanda B, Karuranga S, Unwin N, Colagiuri S, Guariguata L, Motala AA, Ogurtsova K, Shaw JE. Global and regional diabetes prevalence estimates for 2019 and projections for 2030 and 2045: Results from the International Diabetes Federation Diabetes Atlas. *Diabetes research and clinical practice*. 2019 Nov 1;157:107843.
  11. International Diabetes Federation. *IDF Diabetes Atlas, 10th edition: International Diabetes Federation*;2021
  12. Singh S, Yoong M, Kaur A. Offloading techniques for diabetic foot. *J Diabetes Metab Disord Control*. 2017;4(3):00112.
  13. Bus SA, Valk GD, Van Deursen RW, Armstrong DG, Caravaggi C, Hlaváček P, Bakker K, Cavanagh PR. The effectiveness of footwear and offloading interventions to prevent and heal foot ulcers and reduce plantar pressure in diabetes: a systematic review. *Diabetes/metabolism research and reviews*. 2008 May;24(S1):S162-80.
  14. Anggoro PW, Bawono B, Jamari J, Tauviqirrahman M, Bayuseno AP. Advanced design and manufacturing of custom orthotics insoles based on hybrid Taguchi-response surface method. *Heliyon*. 2021 Mar 1;7(3):e06481.
  15. James McGuire DP, LPed FA, Tyler Coye BA. **EXPERT OPINION.**

16. . Lo WT, Yick KL, Ng SP, Yip J. Numerical simulation of orthotic insole deformation for diabetic foot. *Journal of Fiber Bioengineering and Informatics*. 2015 Jan 1;8(3):401-11.