

# WAVELENGTH DISPERSION COMPENSATION IN RADIO OVER FIBER USING FIBER BRAGG GRATING

THESIS REPORT

*Submitted in partial fulfillment of the requirements for the award of the  
Degree of Master of Technology in Electronics and Communication  
Engineering with specialization in Communication Systems by the  
A P J Abdul Kalam Technological University*

*by*

NEELIMA VIJAY

Reg.No TKM21ECCS08



DEPARTMENT OF ELECTRONICS AND COMMUNICATION  
ENGINEERING

TKM COLLEGE OF ENGINEERING

KOLLAM 691 005

MAY 2023

# WAVELENGTH DISPERSION COMPENSATION IN RADIO OVER FIBER USING FIBER BRAGG GRATING

THESIS REPORT

*Submitted in partial fulfillment of the requirements for the award of the  
Degree of Master of Technology in Electronics and Communication  
Engineering with specialization in Communication Systems by the  
A P J Abdul Kalam Technological University*

*by*

NEELIMA VIJAY

Reg.No TKM21ECCS08



DEPARTMENT OF ELECTRONICS AND COMMUNICATION  
ENGINEERING

TKM COLLEGE OF ENGINEERING

KOLLAM 691 005

MAY 2023

**DEPARTMENT OF ELECTRONICS & COMMUNICATION  
ENGINEERING**

**TKM COLLEGE OF ENGINEERING**

**KOLLAM 691 005**



**CERTIFICATE**

Certified that this Project report titled **”WAVELENGTH DISPERSION COMPENSATION IN RADIO OVER FIBER USING FIBER BRAGG GRATING”** is a bonafide record of the work done by **NEELIMA VIJAY** (Reg.No.TKM21ECCS08) under my supervision, in partial fulfillment of the requirements for the award of the Degree of Master of Technology in Electronics and Communication Engineering with specialization in Communication Systems by the A P J Abdul Kalam Technological University.

**Guide**

**Prof.SANIYA AZEEM**

Assistant Professor

Dept. of ECE, TKMCE

**Coordinator**

**Dr. NISHANTH N**

Professor

Dept. of ECE, TKMCE

**HoD**

**Prof.SHABEER S**

Head, Dept. of ECE

TKMCE

# Acknowledgements

At the outset, I consider it my duty to thank Almighty God for giving me the necessary wisdom to successfully complete this project presentation.

I thank **Prof. SHABEER S**, HOD, Department of Electronics and Communication, for his encouragement and support.

I express my sincere thanks to our PG coordinator, **Dr. NISHANTH N**, Professor, Department of Electronics and Communication Engineering, for the support and encouragement during the course of this presentation.

I take this opportunity to express my sincere gratitude and profound thanks to my guide, **Prof. SANIYA AZZEM**, Assistant Professor, Department of Electronics and Communication, for her advice, supervision and patience during the course of project preparation and presentation and for providing me guidance and critical inputs in the preparation and presentation of my project.

I would also like to express my sincere gratitude to all my teachers, friends and my parents for their much needed support during the preparation and presentation of the project.

**NEELIMA VIJAY**

TKM21ECCS08

# ABSTRACT

The light signal in the Radio-over-fiber (RoF) method is modulated by a radio signal to permit long distance communication. In order to boost the capacity of RoF systems, WDM (wavelength division multiplexing) technology can be utilized in the optical fiber feeder network. RoF has nonlinear consequences like dispersion despite its benefits, which can be reduced by choosing the right dispersion control strategies. The use of dispersion management technique which provide greater efficiency for long haul optical networks. In this work we use the Optisystem version 20.0 software has to analyse an improved 32 channel WDM-based RoF optical system that incorporates DCF and FBG as dispersion compensators and can transmit data at 6 Gbps per channel while providing the best signal reception over distances of 120 km. Maximum Q factors of 18.38 were attained in 32 channel mode for constricted 50 GHz channel spacing with a corresponding input power of -5dBm. We also Analysed the impact of varying the grating structures of FBG such as chirped and uniform and discovered that the chirped FBG shows better results in terms of Q-factor.

*Keywords:* Radio over Fiber (RoF), Fiber Bragg Grating(FBG), Chirped Fiber Bragg Grating(CFBG), Uniform FBG, Q-factor, BER.

# Contents

<b>List of Figures</b>	<b>iv</b>
<b>List of Tables</b>	<b>v</b>
<b>1 Introduction</b>	<b>1</b>
<b>2 Literature Review</b>	<b>6</b>
<b>3 Proposed Model</b>	<b>11</b>
3.1 Set Up Of The Proposed 32 Channel WDM-RoF System . . . . .	11
3.2 Software Tool Used . . . . .	12
<b>4 Simulation and Results</b>	<b>14</b>
4.1 Simulation of 32 channel WDM-RoF System . . . . .	14
4.1.1 Results of 32 channel WDM-RoF system without FBG . . . . .	17
4.1.2 Results of 32 channel WDM-RoF system with FBG . . . . .	19
4.2 Simulation of a 32 channel WDM-RoF system using Chirped FBG . . . . .	22
4.2.1 Results of 32 channel WDM-RoF system with Chirped FBG . . . . .	23
4.3 Simulation of a 32 channel WDM-RoF system using Uniform FBG . . . . .	25
4.3.1 Results of 32 channel WDM-RoF system with Uniform FBG . . . . .	26
4.4 Comparison Chart . . . . .	27
<b>5 Conclusion</b>	<b>28</b>
<b>6 Future Scope</b>	<b>29</b>
References . . . . .	33

# List of Figures

1.1	Basic architecture of Radio over Fiber . . . . .	2
1.2	Basic architecture of WDM . . . . .	3
1.3	Schematic diagram of an FBG . . . . .	4
3.1	Simulation block diagram of WDM-RoF system . . . . .	12
4.1	Simulation of proposed 32 channel WDM-RoF transmitter . . . . .	14
4.2	Simulation of proposed 32 channel WDM-RoF transmission medium . . . . .	16
4.3	Simulation of proposed 32 channel WDM-RoF receiver . . . . .	16
4.4	Simulation of 32 channel WDM-RoF system . . . . .	17
4.5	Eye diagram for channel 8 keeping 50 GHz channel spacing with an input power of -5dBm . . . . .	18
4.6	Eye diagram for channel 16 keeping 50 GHz channel spacing with an input power of -5dBm . . . . .	18
4.7	Eye diagram for channel 32 keeping 50 GHz channel spacing with an input power of -5dBm . . . . .	18
4.8	Eye diagram for 8th channel WDM-RoF system with FBG . . . . .	19
4.9	Eye diagram for 16th channel WDM-RoF system with FBG . . . . .	19
4.10	Eye diagram for 32 channel WDM-RoF system with FBG . . . . .	20
4.11	Plot of Bitrate v/s Q-factor . . . . .	20
4.12	Bitrate v/s BER . . . . .	21
4.13	Power in dBm v/s Q-factor . . . . .	21
4.14	Simulation of proposed WDM-RoF System with Chirped FBG in an optical medium . . . . .	23
4.15	Eye diagram for 8th channel system keeping 50 GHz channel spacing with CFBG . . . . .	23

4.16 Eye diagram for 16th channel keeping 50 GHz channel spacing with CFBG . . . . .	23
4.17 Eye diagram for 32nd channel keeping 50 GHz channel spacing with CFBG . . . . .	24
4.18 Channel Frequency v/s Q-factor-50GHz . . . . .	24
4.19 Channel Frequency v/s Q-factor-75 GHz . . . . .	25
4.20 Channel Frequency v/s Q-factor-100GHz . . . . .	25
4.21 Simulation of proposed WDM-RoF System with Uniform FBG in an optical medium . . . . .	25
4.22 Eye diagram for channel 8 at 50 GHz channel spacing for traversal of 120 km . . . . .	26
4.23 Eye diagram for channel 16 at 50 GHz channel spacing for traversal of 120 km . . . . .	26
4.24 Eye diagram for channel 32 at 50 GHz channel spacing for traversal of 120 km . . . . .	27
4.25 Performance Comparison with FBG, Chirped FBG, Uniform FBG with- out FBG . . . . .	27

# List of Tables

4.1	Simulation Parameters . . . . .	16
4.2	Performance evaluation in terms of Q-factor BER by varying channel spacing . . . . .	21
4.3	Performance evaluation in terms BER by varying channel spacing . . . . .	25

# Chapter 1

## Introduction

The need for both wired and wireless networks is constantly exponentially increasing throughout the global telecommunications industry, necessitating the use of technologies that can carry large amounts of data quickly. Data rates have significantly increased in recent years as a result of the steady rise in demand for wired and wireless networks [1]. Radio over Fiber (RoF), which is a primary access network solution for high-speed communication systems, uses optical fibre to transmit radio signals [2]. Long distance travel brings severe distortions and non-linearities into optical fiber transmission systems, which are used to transport data at rates of many gigabits per second. The optical signal weakens during long-distance transmissions as a result of several fiber losses, which ultimately reduces signal intensity. Chromatic dispersion (CD), polarisation mode dispersion (PMD), and attenuation distortions harm the transmitted signal's quality and decrease system efficiency. Currently, radio signals and optical fiber networks are being combined to create the fifth generation (5G) of mobile phone networks, which aims for increased capacity and improved cost effectiveness in the current system design.

Radio over Fiber (RF over Fiber) is an analogue transmission over fibre technology that enables wireless access by amplitude modulating light and transmitting it over an optical fibre link. The major objective of RoF was to provide a different approach to millimetre-wave(mm-wave) ultra-broadband wireless signal delivery [3-4]. The wireless signal in a RoF system is first exchanged optically between a central station and a number of base stations before being disseminated over the environment. Each base station is built to establish a radio link with at least one nearby and within the base

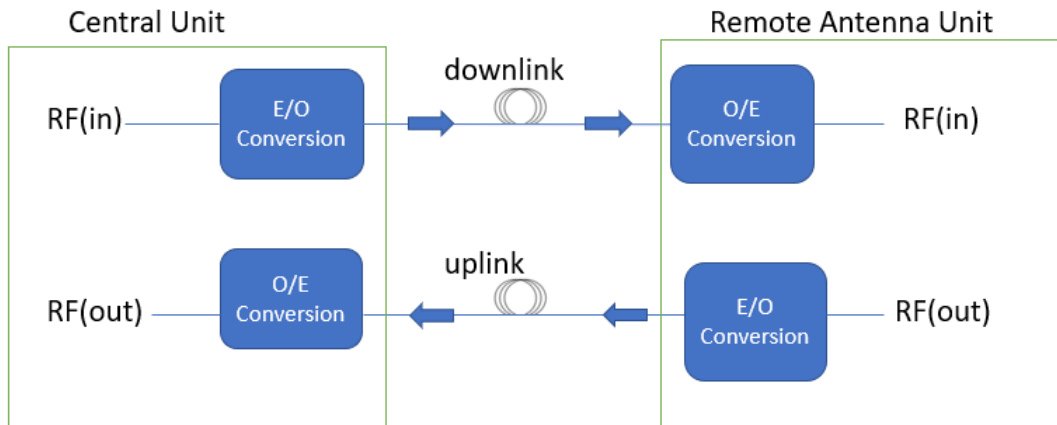

Figure 1.1: Basic architecture of Radio over Fiber

station's radio coverage area user's mobile station. In RoF, RF over fiber and IF over fiber are the two categories based on frequency range. When using RF over fiber, a light wave signal is superimposed with a high frequency that is more than 10GHz RF signal that carries data before being transmitted through the optical fiber link. When using IF over fiber, the light is first sent across the optical link and modulated with a radio signal that has a lower frequency which is less than 10GHz. This enables to create centralized control, which supports the optical distribution and transmission of wireless signals.

Figure 1.1. illustrates the basic architecture of Radio over Fiber. A central station and base station are required for RoF. The primary signal generation occurs at the central station, where baseband signals are also produced using an appropriate modulation. After then, the signal is sent via the fiber. There will be an optical to electrical and electrical to optical conversion when the signal reaches the base station in every RoF system. Low power consumption, a large bandwidth that enables many radio channels to be multiplexed, the ability to transmit the radio signal through already-existing dark or dim fibers, and intrinsic immunity to electromagnetic interference are all benefits of RoF technology. Because the RF to optical modulation frequently occurs independently of the base band to RF modulation, there is often no interference and transparent operation.

RoF and WDM work together to improve the efficiency of network application access at high speeds. Even in remote locations, cellular connection is improved

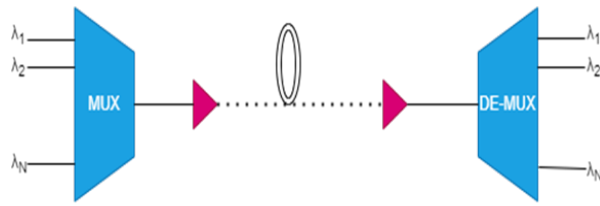

Figure 1.2: Basic architecture of WDM

by combining RoF and WDM technologies. In WDM, numerous wavelengths pass through a single optical fiber while carrying various signals at various wavelengths. As a result, many wavelength-dependent signals are mixed, sent across a single optical cable, and then separated at the other end as shown in Figure 1.2. This leads to a high data rate, a higher system capacity, greater flexibility, lower costs, and a straightforward network design, all of which contribute to an improved optical communication system in all its forms.

Dispersion is the term used to describe how differently coloured light (light with different frequencies) travels through an optical fiber at varying rates of speed. The light is enlarged because long-wavelength light expands slowly and short-wavelength light expands quickly, causing them to be separated from one another. The system performance will also be impacted by the cross talk that would result from this. The transmission rate limitation illustrates how fiber dispersion affects the effectiveness of the communication system. The relay distance must be shortened in order to maintain communication quality because dispersion will become more and more problematic as transmission distance rises. Dispersion compensation technology is crucial for optical communication systems because it may be used to correct dispersion and nonlinear distortion. In optical communication systems, Fiber Bragg Grating (FBG) is frequently used as crucial components to account for dispersion. It has a tailored reflection spectrum and a large bandwidth due to the low cost of the wavelength selection filter and minimal insertion loss. The distributed Bragg reflector known as a fiber bragg grating reflects specific wavelengths of light while transmitting all other wavelengths. This is accomplished by periodically changing the fiber core's refractive index, which results in the creation of a dielectric mirror that is tuned to a certain wavelength. It is often made using a phase mask technique, which involves subjecting a single mode fiber to a strong optical interference pattern. Coherent scattering on

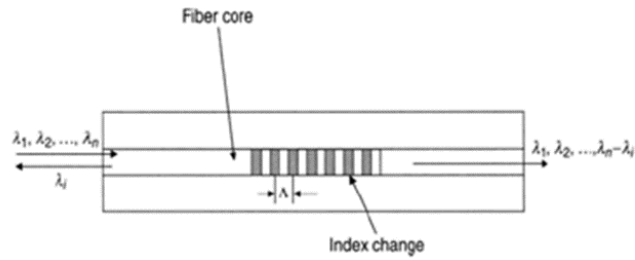

Figure 1.3: Schematic diagram of an FBG

variations in the refractive index causes a portion of the incident light's narrow band to be reflected. The maximum wavelength that can be reflected while having a strong contact with the input light is that wavelength. Consequently, an in-line optical fiber with a fiber Bragg grating can be used to block particular wavelengths.

Schematic diagram of an FBG is shown in Figure 1.3. The fiber should have a core portion and a cladding. The refractive index of the core changes periodically with a period. When light with multiple wavelengths launched in FBG, only one particular wavelength is in phase with the grating period, this wavelength is reflected back to the input side and other will transmit. Both the fiber's core and cladding should be present. The core's refractive index varies irregularly throughout time. Only one specific wavelength of light that is launched into the FBG is in phase with the grating period, this wavelength is reflected back to the input side while the other wavelengths transmit. Fresnel reflection, where light traveling between mediums with differing refractive indices may both reflect and refract at the interface, is the underlying idea behind how an FBG works. Refractive index or grating period are two ways to change the FBG's structural makeup. The grating period can be localized or dispersed in a superstructure, and it can also be uniform or graded. The offset and the refractive index profile are the refractive index's two main properties. In most cases, the refractive index offset is positive or zero, and the refractive index profile can be uniform. Chirped FBG and Uniform FBG are the various grating structures of an FBG. A chirp, which is a linear fluctuation in the grating period, is one of the additional features that can be added to the grating's refractive index profile. With increasing grating period, the wavelength reflected broadens the reflected spectrum. While in a Uniform FBG, the grating period varies uniformly along the length of the fiber.

In this paper we are adopting a 32 channel WDM-based RoF system with an FBG as dispersion compensator is capable of transmitting at a bit rate of 6 Gbps per channel and providing the best signal reception across a 120 km range. The suggested system has been tested using the Opti system 20.0 simulation program, and it has been discovered to provide outstanding transmission quality in terms of Q-factor BER, at receiving end. We modify an FBG's grating structure into a chirped and uniform for better performance in order to achieve long distance transmission of the proposed 32 channel system. Fiber that has been chirped due to their enormous potential for usage as dispersion equalizers in long-distance fiber telecom network. The system can effectively adjust for the effects of inter-channel crosstalk provided by the WDM scheme and maintain superior signal transmission quality, according to channel spacing variations from 50 GHz to 100GHz.

# Chapter 2

## Literature Review

This section presents an overview of some works related to the proposed approach.

According to Bhattacharjee *et.al.*, and [5] is based on an improved 32 channel 256 Gbps DWDM-based RoF optical system with the ability to transmit data at 8 Gbps per channel and provide the best signal reception over distances of 60 km and 120 km, the integration of DCF and FBG as dispersion compensators has been examined. When used in 8 channel mode with a 4 Gbps per channel bit throughput, the suggested system achieved a very high Q factor of about 79 for 50 GHz channel spacing. The observed spectra also demonstrated a significant 6 dBm reduction in FWM side band power level. The transmission quality was shown to be significantly superior than the existing WDM-RoF systems for long distance traversal (120 km) and constrained channel spacing (50 GHz). Here they also do the comparative study with the existing two RoF systems. First off, the suggested technique produced a fantastic Q factor of roughly 79 for when used in 8 channel mode at 4 Gbps per channel bit rate and 50 GHz channel spacing, lowering FWM side band power level by an average of 6 dBm, as seen from the measured spectra. Second, the simulated 32/256 DWDM-RoF system achieved much higher values of Q factor and BER, especially for constrained channel spacing, when compared to another current 16 channel RoF system (50 GHz). Consequently, it can be concluded that compared to the current WDM-RoF systems, the proposed DWDM-RoF system is significantly more efficient for long-distance transmission at 50 GHz channel spacing.

A.Kumar *et.al.*, [6] investigate to lessen the influence of non-linear transmission effects, notably Four-Wave Mixing (FWM), using an effective 8-channel 32Gbps RoF

(Radio over Fiber) system integrating Bessel Filter (8/32 RoF-BF). They tried to mitigate the nonlinear effect by varying the input power, channel spacing and number of channels. The simulation results show that the suggested 8/32 RoF-BF system achieves the best results in terms of input channel number (8), input source power (0 dBm), and channel spacing (75 GHz). Based on their findings, it has been found that the FWM effect diminishes as the channel spacing and signal source power are both increased. Bessel filter integration results in a significant reduction of the FWM sideband power by 4 dBm.

Munshid *et.al.*, [7] focused on the investigation and performance analysis of external direct modulation, fluctuations in Q-factor, and BER with regard to fiber length at wavelength 1310 nm using the simulation software. Based on the results of the simulation, it can be seen that the suggested system performs as required with an external scheme. Additionally, for the given system recommended the best bit rate/fiber length trade-off. The system with external modulation performed better in terms of maximum data rate and 10 km fiber length. Low BER and good eye diagrams were obtained, indicating improved system performance. With external modulation, the suggested system can handle high bit rates and fiber lengths of 2 to 10 km.

H. Ahmed *et.al.*, [8] adopts RoF transmission for an optical fiber that is 100 km long, operating at a 1 Gb/s data rate, and modulated using the DPSK modulation technique. Performance is assessed using metrics like BER and Q factor. Additionally, using FBG in a dispersion compensation fiber scheme can improve the performance. And contrast the configuration of the 100 km RoF with DPSK modulation with FBG, DCF, and DCF FBG. Design and simulation are done for an effective RoF system using DPSK modulation and dispersion compensating fiber. The parameters for several dispersion compensating fiber approaches are assessed and contrasted, including maximum Q-factor, minimum BER, eye height, and threshold. The performance analysis is assessed using Opti System version-10 software. The results show that the suggested system might run more effectively when it used DPSK modulation in conjunction with DCF and FBG. Additionally, the results show that the system has a lot of potential for contemporary applications like upcoming wideband multimedia. However, the systems support a variety of functions that are necessary for wireless access.

M.Chakkour *et.al.*[9], To combat chromatic dispersion and attenuation issues, an optical transmission system utilizing Fiber Bragg Grating (FBG) and an Erbium Doped Fiber Amplifier (EDFA) has been examined. In the first step, a straightforward model of one channel transmission has been built to assess the transmission system performance of the received signals. Further, optical to deal with the optimal corresponding parameter values, fibre length and attenuation coefficient parameters have been thoroughly studied. In terms of output power (dBm), noise figure (dB), gain (dB), and Q-Factor, the results demonstrate that the performance of the optimized design parameters is very efficient. Using the previously produced model of one channel, a complex model of four optical channels multiplexing with different wavelengths has been created. FBG and EDFA are used in the suggested paradigm to combat chromatic attenuation and dispersion issues. The recommended method was initially tested in the simple scenario of one channel transmission in order to identify the appropriate parameter value of the attenuation coefficient. After being put to the test utilizing the suggested model in a WDM optical transmission system, the results of the developed method continue to yield reliable results. Less signal distortion, better gain, and stronger output are all features of the new model. Additionally, when the model's results were compared to those of a WDM technology system, it was discovered that the new system's Q-Factor is 4 times more significant at 50 GHz than other systems' Q-Factors, with higher efficiency on the received signal quality and a lower noise ratio.

[10] G. Kaur *et.al.*, describes Radio over fiber (RoF), a hybrid of optical and wireless technologies, has two benefits: a high information rate and increased mobility. It suggests a full-duplex RoF passive optical network (PON) based on wavelength remodulation of fiber Bragg gratings. The system's simulation demonstrates that the 1Gbps uplink and 1Gbps downlink communications (CS) share the continuous wave (CW) laser source of the remote central station. The results show that the network performance is improved (DCF) by lowering the total dispersion of the fiber link using FBG and dispersion compensating fiber. The technology has been trouble-free up until this point and can enable long-haul transmission across a 100-kilometer distance. A full-duplex RoF architecture and a wavelength reuse method are offered in order to increase the number of users. The same wavelength has been used twice without the

use of a different light source. The cost of the overall system is reduced as a result, simplifying the design of BS. By increasing the number of users on the network, the system cost can be reduced even more. The performance of the system is improved by reducing the total dispersion of the fiber link utilizing FBG and DCF. The system has acceptable BER values and can receive electricity at transmission distances of up to 100 km.

Fahd Chauoi *et.al.*, [11] Chirped fiber bragg grating (FBG) has been created in order to reduce the nonlinear effects of dense wavelength division multiplexing (WDM) for optical long-haul networks. This technique has been investigated based on different chromatic dispersion values. The method aims to reduce the FWM nonlinear effects in dense WDM optical networks, chromatic dispersion issue or not. Handling FWM and Chromatic dispersion in optical fibers provides a lot of difficulties because they are inversely proportionate. It would be ideal if a module could fix these two major issues at once. The WDM transmission system is modeled using the powerful capabilities of Optisystem 7.0. At the 8-channel WDM long-haul network, the Chirped FBG technology has been developed and investigated for this purpose using optical spectrum analysers and eye diagrams. Investigators analyzed the simulation data and found that FWM nonlinear effects are inversely related to chromatic dispersion. Two optical communication scenarios, the first with minimal chromatic dispersion and the second with high dispersion values have been the focus of the performance analysis of the suggested approach. According to the simulation results, the suggested approach using Chirped FBG provides strong chromatic dispersion compensation and decreased FWM nonlinear effects.

[12] A.Mohan *et.al.*, Radio over Fiber (RoF) is a technology that enables wireless access and transmission by modulating light with radio frequency signals and transmitting them through optical fibre. Due to its wide bandwidth and low attenuation properties, the convergence of wired and wireless networks is a viable solution for the rising demand for transmission capacity and flexibility. It also offers financial benefits. Wavelength Division Multiplexing (WDM) and Optical Add Drop Multiplexer (OADM) allow for the full duplex transmission of RoF over long distances. WDM enables the transmission of various signals through a single mode fibre, while OADM allows for the transmission of both down-link and up-link data over the same single-

mode fibre. Various line coding techniques such NRZ RZ are used also encoding techniques are compared with Q factor and BER. WDM makes it possible to send several signals through a OADM allows for the simultaneous transmission of downlink and uplink data across a single mode fibre over long distances. Analysis is done on the performance of the RoF system with various user and base station counts, RZ and NRZ modulations, and different digital modulation formats. All of the simulations achieve a higher Q factor and a lower BER, which suggests that the system will function better. The optical spectrum of NRZ pulses is constrained. Although the dispersion tolerance is improved by the narrower spectrum, inter-symbol interference results. The RZ pulse has a duty cycle that is less than 1 and a wide spectrum because it only takes up a small portion of the bit slot. Using the RZ pulse shape, one can greater resistance to the impacts of Polarization Mode Dispersion (PMD) and fibre non-linearities. According to the investigation, RZ modulation performs better for high bit rate and long-distance applications.

M.A. Othman *et.al.*,[13] describes due to its properties, which include tiny size or dimension, low loss, and little interference from the outside environment, optical fiber is always employed in telecommunication systems. While there are many different kinds of optical fiber, Fiber Bragg Gratings (FBG) are frequently selected as crucial parts to mitigate dispersion in optical communication systems. FBG is relatively straightforward, has an inexpensive wavelength selector filter, a low insertion loss, a tailored reflection spectrum, and a wide bandwidth. By examining the impact of the components in the data receiver by utilizing different parameter settings, the simulation of the optical transmission system in optical fiber has been explored. A number of characteristics, including output power (dBm), noise figure (dB), attenuation coefficient (dB/km) at the cable segment, and gain (dB) at the receiver, have had their values examined. It is possible to get the conclusion that the attenuation coefficient and optical fiber length are directly proportional to the noise figure. The noise figure quantifies the amount of noise that the amplifier introduces into the signal. While the gain decreases as the length increases. However, because EDFA is being used and the gain has been compressed, the output power is decreased even though the input power is increased.

# Chapter 3

## Proposed Model

In order to achieve better transmission quality for long haul traversal of 120 km in optical fiber transmission system ,we first tried to simulate a 32 channel WDM-RoF system with a hybrid combination of DCF and FBG. As a result, we first analyse the performance in terms of Q-factor and BER by using Opti system software. Then we tried to change the grating structures of FBG such as Chirped FBG Uniform FBG for improving the transmission quality in an optical fiber communication system.

### 3.1 Set Up Of The Proposed 32 Channel WDM-RoF System

Figure.3.1. shows the block diagram of the proposed 32 channel WDM-RoF system. Here the proposed system mainly classifies into three sections. A transmitter section, transmission medium and receiver section. The transmitter with 32 channel having different wavelength is multiplexed by WDM multiplexer and the multiplexed signal is then fed to transmission medium. There are some nonlinearities and inherent dispersion that restrict the maximum traversal. In addition to fiber losses, dispersion and non-linearities are further problems with optical fiber communication systems. Dispersion reduces a system's ability to convey information, reduces its operational bandwidth, and raises the bit error rate (BER). Fiber Bragg grating (FBG) is utilized as a low-cost wavelength selection filter in order to compensate for dispersion. To counteract the effects of positive dispersion in an optical fiber communication

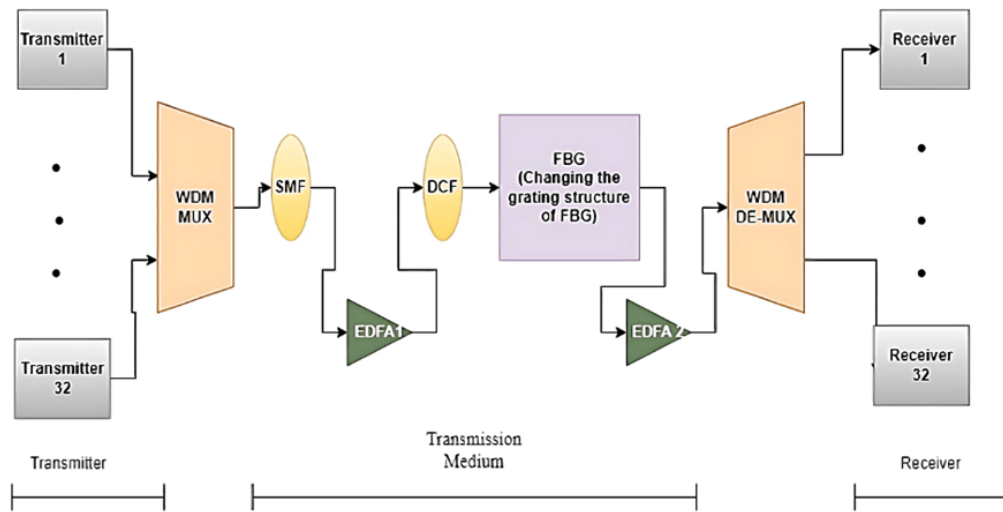

Figure 3.1: Simulation block diagram of WDM-RoF system

link, Dispersion Compensation Fiber (DCF) with a negative dispersion coefficient is introduced. Although the DCF technique increases negligible nonlinear effects, it is inexpensive, straightforward, extremely reliable, and simple to upgrade single-mode fiber (SMF) links that have already been installed in an optical network. And also we change the grating structures of FBG such as Chirped FBG(CFBG) and Uniform FBG to increase the system performance and transmit the signal into long distance with less distortion. A chirp, which is a linear fluctuation in the grating period, is one of the additional features that can be added to the grating's refractive index profile. With increasing grating period, the wavelength reflected broadens the reflected spectrum. While in a Uniform FBG, the grating period varies uniformly along the length of the fiber. WDM-DEMUX is used at the receiver side to demultiplex signals before sending them to various receivers.

## 3.2 Software Tool Used

Optisystem version 20.0 is the software environment that we used for simulation and verification. It is a modeling tool for optical communication systems that enables nearly any type of optical channel to be designed, screened for, and optimized in the physical layer of a variety of optical networks, from intercontinental backbones to analogue video broadcasting systems. The realistic modeling of fiber optic communication

networks serves as the foundation for OptiSystem, a system level simulator with a solid simulation platform and a genuinely structured specification of components and systems. Its capabilities can easily be extended by adding user components and fluid user interfaces to a range of regularly used programs.

The configuration, testing, and reconstruction of optical links in cutting-edge optical systems are made possible by this programming framework package. The Optisystem Component Library has a large number of components that let you add parameters that can be measured from equipment. It has connections to test and measurement equipment made by different companies. Optisystem supports mixed signal formats for optical and electrical signals in the component library. It calculates the signals using the appropriate methods in proportion to the required simulation accuracy and efficiency. According to the needs of the project, we can also combine external applications like Matlab, Python, etc.



for use in various optical networks. The optical carrier signal with a frequency range of up to 193.1 THz–194.75 THz is produced by the CW laser with a power range of -5dBm utilizing the MZM, and the encoded message signal is overlaid over it. The MZM and Erbium Doped Fiber Amplifier (EDFA) improve long-haul communication performance metrics by coupling higher optical output power into SMF, allowing for higher transmission rates, and reducing chirp and increasing compatibility with EDFA. After modulation, a WDM unit multiplexes the optical output signals from many CW laser transmitters operating at different wavelengths to increase capacity. So, the multiplexed signal then feeds to the transmission medium.

Then the transmission medium as shown in Figure.4.2. It mainly consists of a Single Mode Fiber (SMF), dispersion compensation schemes and optical amplifiers are there. In comparison to Multi-Mode Fiber (MMF), SMF also transmits the multiplexed optical signal over a larger distance, but its intrinsic nonlinearities and dispersion limit the maximum traversal. Optical amplifiers, DCF, and FBG have been sequentially installed in the optical network to increase the traversal limit for lossless transmission. As an in-line amplifier, the first amplifier in this link enhances the weak incoming signal to a predetermined level. The design includes an EDFA because it offers the necessary optical amplification with the least amount of extra noise. The signal is amplified before being supplied to the DCF, which offers link dispersion and equal and opposite dispersion ranging from -83.75 ps/nm-km to chromatic dispersion of zero. The optical receiver needs to have a pre-amplifier in front of it in order to meet demands for increased receiver sensitivity and SNR. As a result, the second EDFA serves as a pre-amplifier with high gain and low noise levels. Bessel Filter must be used in the optical fiber link's architecture. Bessel filters are used in design because they have characteristics like a maximum amount of flat group delay, gradual cut-off and overshoot, most significantly, they maintain the wave shape of filtered signals in the pass band, which directly results in the best phase response.

Figure 4.3. shown below is the simulation of proposed 32 channel WDM-RoF receiver subsystem. Then the receiver device receives the filtered optical signal. The receiver unit includes a bit error rate (BER) analyser, a filter, and a PIN photo detector. In order to remove the noise produced by the link, the striking optical signal is converted to electrical data in the Positive Intrinsic Negative (PIN) photo

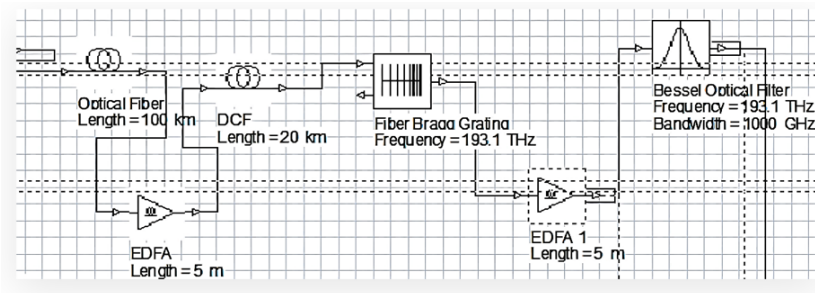

Figure 4.2: Simulation of proposed 32 channel WDM-RoF transmission medium

detector before being filtered using a Low Pass Bessel Filter. The BER analyser is used to assess the eye diagram visual and Q-factor value, which are considered the benchmark performance indicators for signal transmission quality.

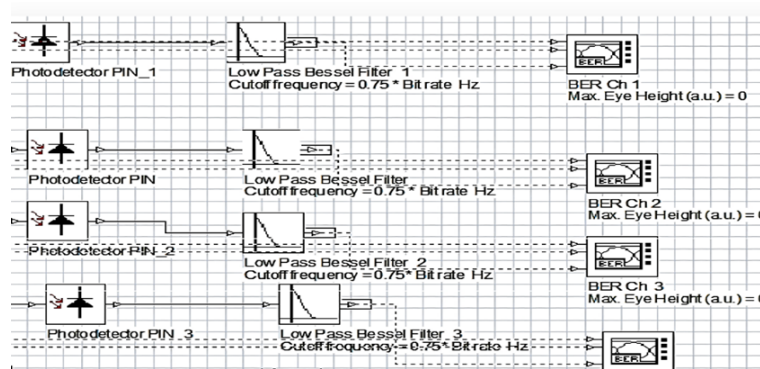

Figure 4.3: Simulation of proposed 32 channel WDM-RoF receiver

Table 4.1: Simulation Parameters

Simulation Parameters	Value
Bit Rate	2-8 Gbps
CW Laser	Power:-5 to 10 dBm, Frequency:193.1-194.75THz
Fiber	Length:100 km, Attenuation: 0.2 db/km
EDFA	Length:5 m
DCF	Length:20 km
FBG	Effective index:1.45,Chirpfunction:Linear
Parameter concerning Receiver	Responsivity: 1 A/W,Filter used- low pass Bessel filter

Table 4.1 shows the simulation parameters used for the proposed work. The bit rate used in this work is 2-8 Gbps. 50 GHz channel spacing gives a frequency range of 193.1-194.75 THz and 100 GHz channel spacing gives a frequency range of 193.1-196.2 THz in a CW Laser source. Then the single mode fiber with a length of 100

km and gives a dispersion of 16.75 Ps/nm-km. The dispersion compensators such as DCF with a length of 20 km and with dispersion of -83.75 Ps/nm-km. FBG act as another dispersion compensator with an effective index of 1.45 with a frequency of 193.1 THz. While changing the grating structure of an FBG as chirped FBG with a linear chirp function and Uniform FBG adopt a bandwidth of 50 GHz. The parameter concerning receiver are low pass Bessel filter with a cut off frequency of  $0.75 \times \text{Bit Rate}$  Hz and a PIN photodiode with a responsivity of 1 A/W.

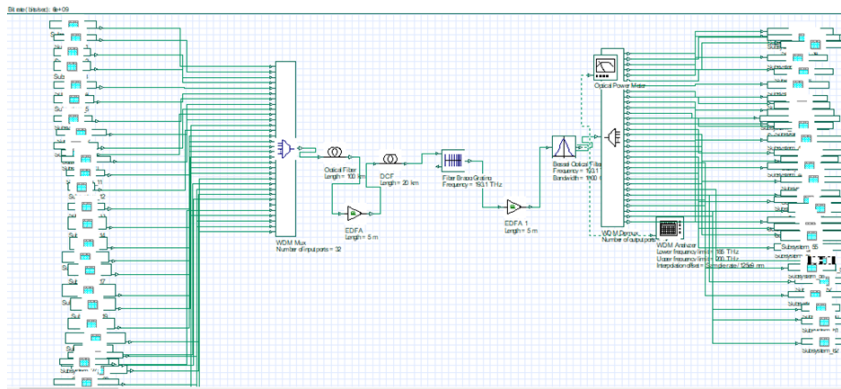

Figure 4.4: Simulation of 32 channel WDM-RoF system

Figure 4.4 was a thirty-two-channel simulation block of WDM-RoF system using FBG. Each subsystem represents the transmitter and receiver section mentioned below. At the transmitter side input signal is modulated. The modulated signal is then fed to the optical medium. Finally, the receiver performance can be analysed with the help of a BER analyser. We selected a bitrate of 6 Gbps and channel spacing of 50 GHz with an input power of -5dBm for the proposed system. The obtained results are described below.

#### 4.1.1 Results of 32 channel WDM-RoF system without FBG

Figure 4.5, 4.6 and 4.7 shows the eye diagram obtained for channels 8, 16, 32 with 50 GHz channel spacing keeping input power of -5 dBm for a transmission distance of 120 km. The Q-factor obtained for channel 8, 16, 32 is 54.53, 46.62, 17.96 respectively. From this channel 8 should acquire the highest Q-factor and channel 32 should acquire the least. In order to reduce the dispersion in the system, Fiber Bragg Grating is incorporated with Dispersion Compensation Fiber and analyze the performance of the system in terms of Q-factor and BER using a BER analyser.

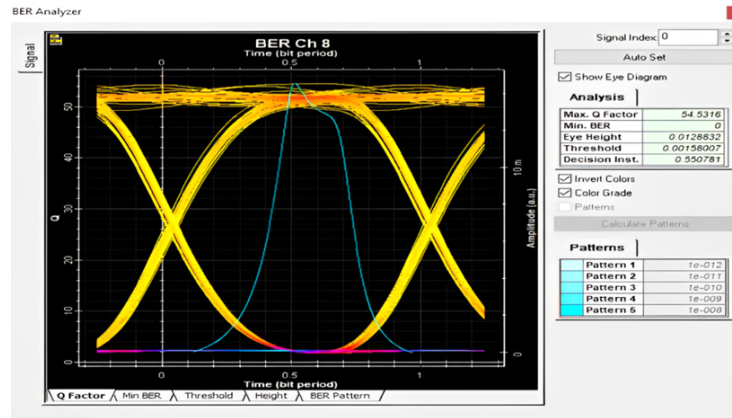

Figure 4.5: Eye diagram for channel 8 keeping 50 GHz channel spacing with an input power of -5dBm

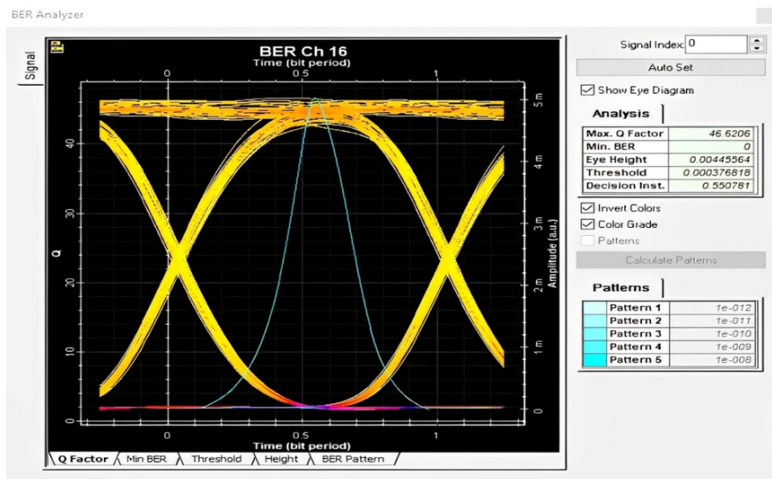

Figure 4.6: Eye diagram for channel 16 keeping 50 GHz channel spacing with an input power of -5dBm

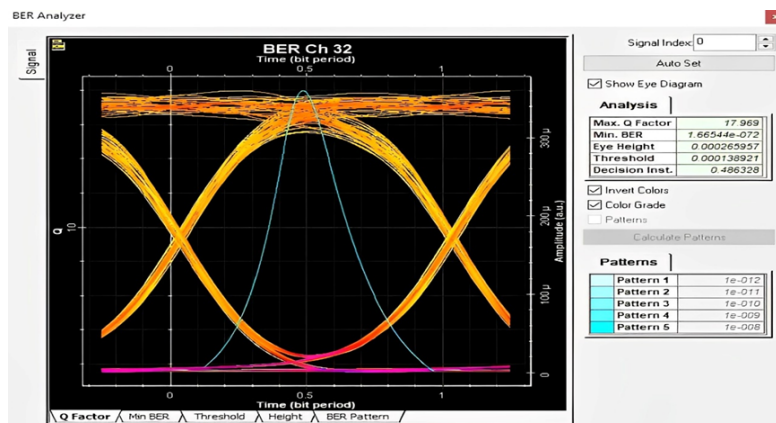

Figure 4.7: Eye diagram for channel 32 keeping 50 GHz channel spacing with an input power of -5dBm

### 4.1.2 Results of 32 channel WDM-RoF system with FBG

Figure 4.8, 4.9 and 4.10. shows the eye diagram obtained for channels 8,16,32 with 50 GHz channel spacing keeping input power -5 dBm for a transmission distance of 120 km. The Q-factor obtained for channel 8, 16 32 is 67.53, 56.77 18.38 respectively. While combining the results obtained without FBG and with FBG in the proposed system, it can be clearly seen that Q-factor obtained is much higher while using FBG in the system. The performance parameter Q-factor is inversely proportional to BER. While using FBG in the system channel 8 should have the lowest BER and highest Q-factor.

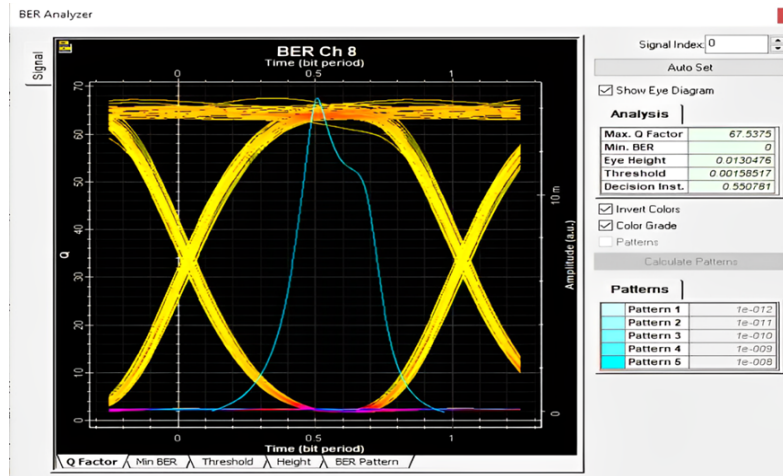

Figure 4.8: Eye diagram for 8th channel WDM-RoF system with FBG

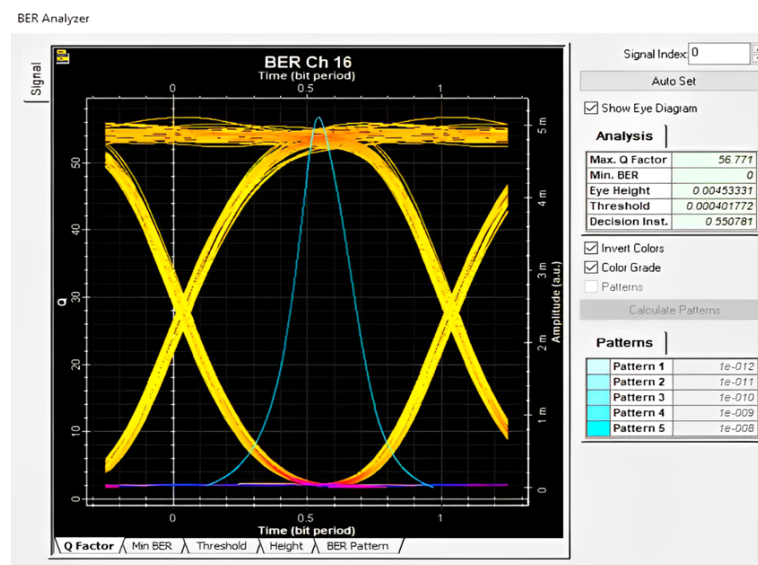

Figure 4.9: Eye diagram for 16th channel WDM-RoF system with FBG

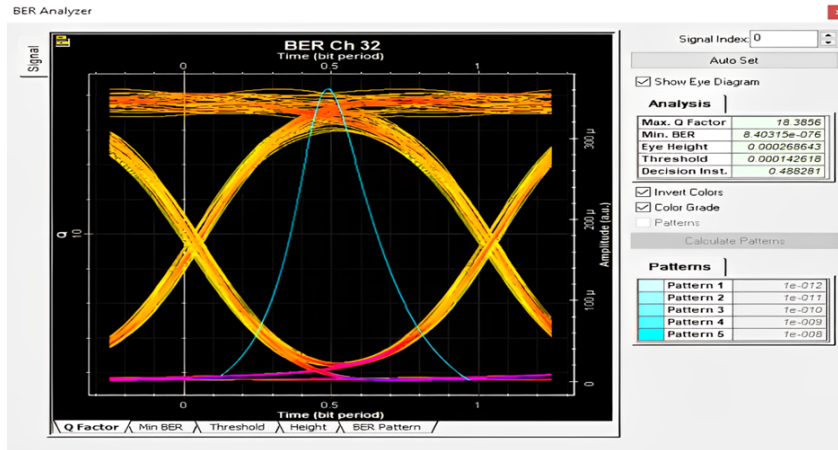

Figure 4.10: Eye diagram for 32 channel WDM-RoF system with FBG

While varying the bitrate from 2Gbps-8Gbps, the Q-factor decreases for each channel. When bitrate increases the Q-factor decreases and BER increases is illustrated in Figure 4.11 and 4.12. The system with lowest bitrate of 2 Gbps should have a good performance. The log BER for a bit rate of 4, 6 8 Gbps is -218.32, -75.07,-32.723.From analysis it can be clearly seen that bitrate is directly proportional to BER.

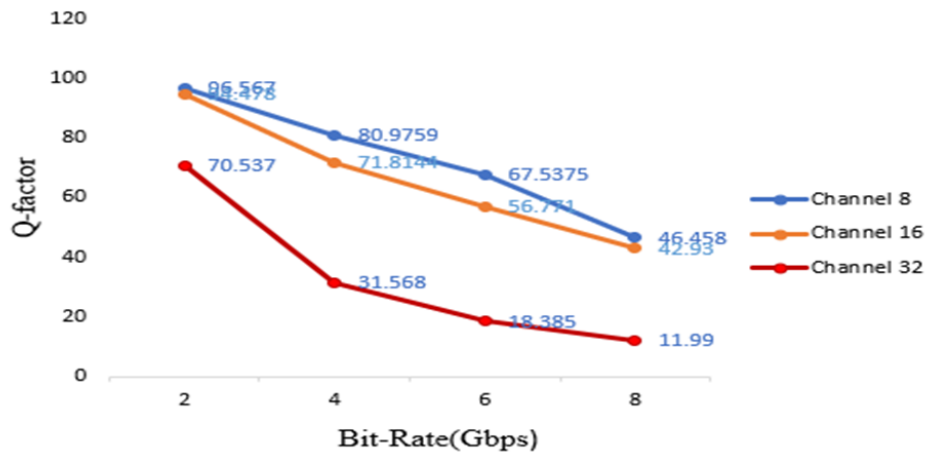

Figure 4.11: Plot of Bitrate v/s Q-factor

Figure.4.13. demonstrates the graphic of Q factor fluctuations for the 8th, 16th, and 32nd channels for a 120 km transmission while maintaining a fixed 50 GHz channel spacing when the input signal’s power is adjusted from - 5 to 10 dBm. It is evident that even with 50 GHz spacing and a wide range of signal power, respectable Q factor values are maintained. It is seen that the Q factor for the channels is maintained for signal strengths between -5 dBm and 5 dBm and exhibits a deteriorating trend outside of this range.

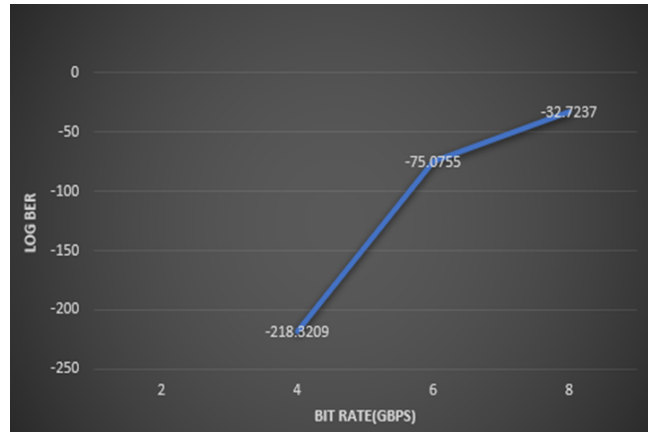

Figure 4.12: Bitrate v/s BER

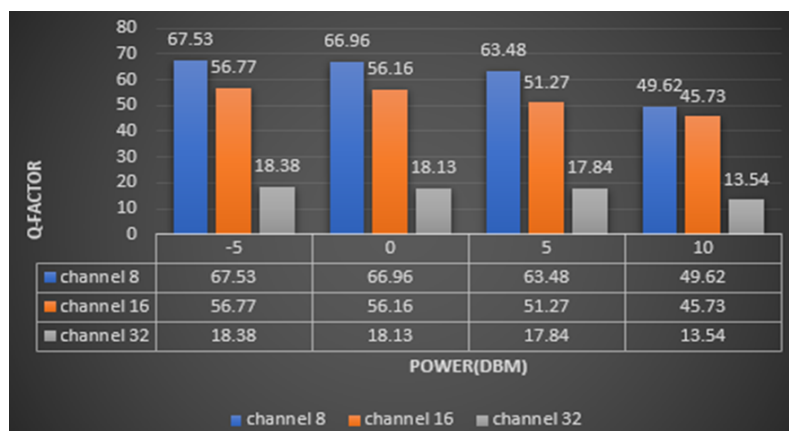

Figure 4.13: Power in dBm v/s Q-factor

Table 4.2: Performance evaluation in terms of Q-factor BER by varying channel spacing

FBG						
Channel Spacing(GHz)	Q-factor			BER		
	C-8	C-16	C-32	C-8	C-16	C-32
50	67.53	56.77	18.38	0	0	8.40E-76
100	40.9414	14.34	5.81	0	5.45E-47	3.03E-09

The Table 4.2. shows the obtained Q-factor and BER for channel 8,16 and 32 by varying the channel spacing of 50 GHz and 100 GHz. From the above mentioned table we analyse that the channel spacing of 50 GHz should have the highest Q-factor than the channel spacing of 100 GHz. From the results it can be seen that the performance of a 32 channel WDM-RoF system with FBG are better for long haul transmission. In order to improve the performance of a 32nd channel, we tried to change the grating structures of FBG such as mainly Chirped FBG and Uniform FBG.

## 4.2 Simulation of a 32 channel WDM-RoF system using Chirped FBG

Dispersion compensation in fiber optic communication networks is another significant application of FBGs. Because the group velocity of the mode depends on the wavelength, dispersion occurs as light pulses travel over an optical fiber link. It is necessary to adjust for this dispersion in the link, which can be done by using chirped FBGs or dispersion compensating fibers. The period of the grating in chirped FBGs varies with the position along the fiber length, which affects the Bragg wavelength along the grating. As a result, various wavelengths are reflected at various locations along the grating, resulting in various temporal delays for various wavelengths. One can account for the differential delay of various wavelengths collected during fiber propagation by employing an appropriate chirped FBG. Refractive index or grating period are two ways to change the FBG's structural makeup. The grating period can be localized or dispersed in a superstructure, and it can also be uniform or graded. The offset and the refractive index profile are the refractive index's two main properties. Typically, the refractive index offset is positive or zero and the refractive index profile can be uniform. In chirped gratings, the optical period of the index modulation varies along the length of the grating. The length of the chirped fiber grating causes a regular shift in the wavelength of the reflected light selected by each filter, which may be thought of as a filter made up of resonant wavelengths distributed according to a particular law. Chirped fiber gratings, which come in linear and nonlinear varieties, are significant non-uniform gratings. Nonlinear fiber grating is nonlinear, while linear chirped grating refers to grating period variations that occur linearly along the axis. In our work, we use a linear chirp function. The linear chirped FBG is a crucial dispersion compensation technique in optical communication systems. Because the grating period varies linearly along the fiber axis, it achieves the function of widening the light pulse. Figure 4.14. shows the simulation of the proposed system with Chirped FBG in an optical medium.

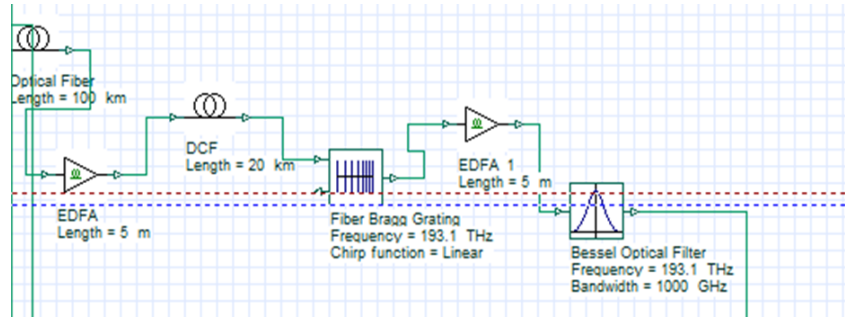

Figure 4.14: Simulation of proposed WDM-RoF System with Chirped FBG in an optical medium

### 4.2.1 Results of 32 channel WDM-RoF system with Chirped FBG

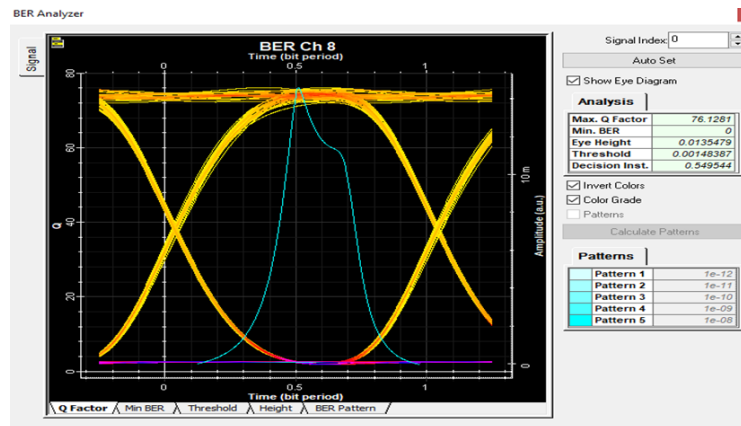

Figure 4.15: Eye diagram for 8th channel system keeping 50 GHz channel spacing with CFBG

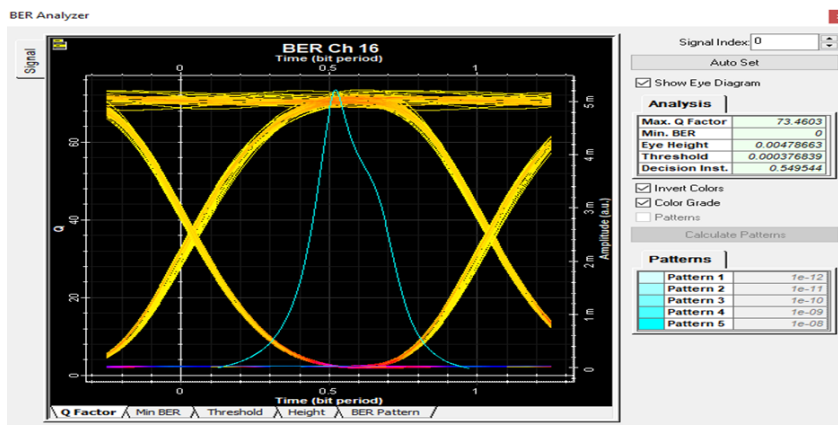

Figure 4.16: Eye diagram for 16th channel keeping 50 GHz channel spacing with CFBG

Figure 4.15, 4.16 and 4.17. shows the eye diagram for channels 8,16,32 with

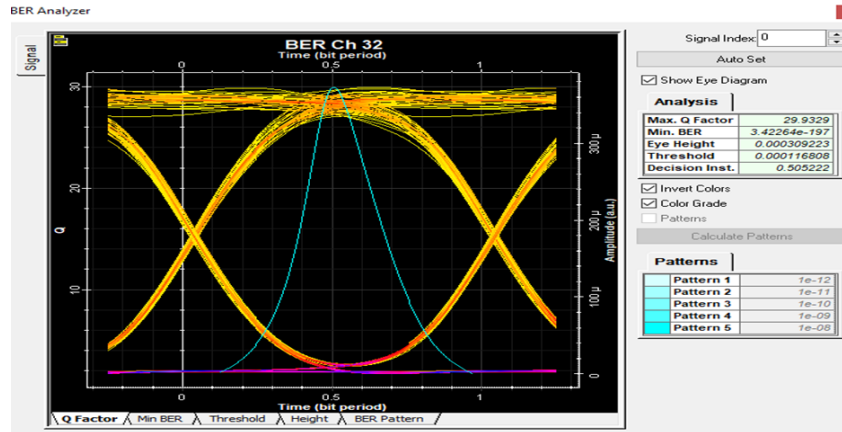

Figure 4.17: Eye diagram for 32nd channel keeping 50 GHz channel spacing with CFBG

Chirped FBG having a channel spacing of 50 GHz with an input power of -5 dBm for a transmission distance of 120 km. An eye diagram’s closure shows the signal waveform being disturbed by noise and symbol interference. An open eye graphic thus represents the least amount of signal disruption. Each figure’s eye-opening shows how the signal quality increases following dispersion adjustment. By using the Chirped FBG, the value of the Q-factor is increased to 29.93 for a 32nd channel.

Plot of channel frequency v/s q-factor with a channel spacing of 50 GHz, 75 GHz 100 GHz using Chirped FBG is illustrated in Figure 4.18, 4.19, 4.20. From the figure we analyse that channel spacing increases q-factor decreases.

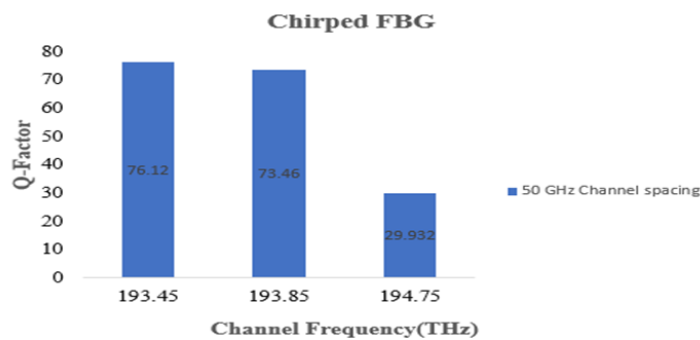

Figure 4.18: Channel Frequency v/s Q-factor-50GHz

From Table 4.3.illustrate the performance evaluation in terms of BER by varying the channel spacing from 50 GHz,75 GHz 100 GHz. So, when channel spacing increases the BER also increases.50 GHz channel spacing gives the highest BER and 100 GHz channel spacing gives the least BER.

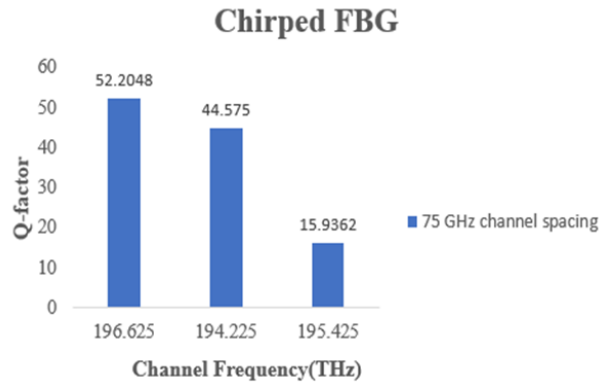

Figure 4.19: Channel Frequency v/s Q-factor-75 GHz

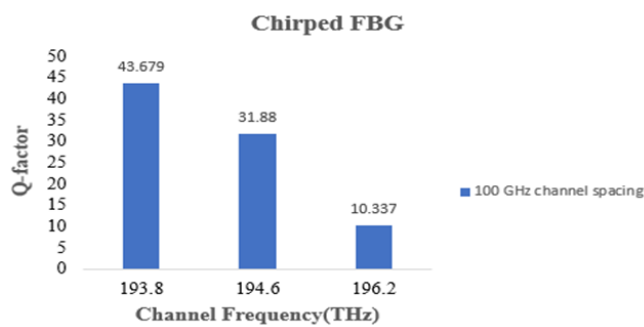

Figure 4.20: Channel Frequency v/s Q-factor-100GHz

Table 4.3: Performance evaluation in terms BER by varying channel spacing

Channel Spacing(GHz)	BER for C-8	BER for C-16	BER for C-32
50	0	0	3.42E-197
75	0	0	1.59E-57
100	0	2.03E-223	2.46E-25

### 4.3 Simulation of a 32 channel WDM-RoF system using Uniform FBG

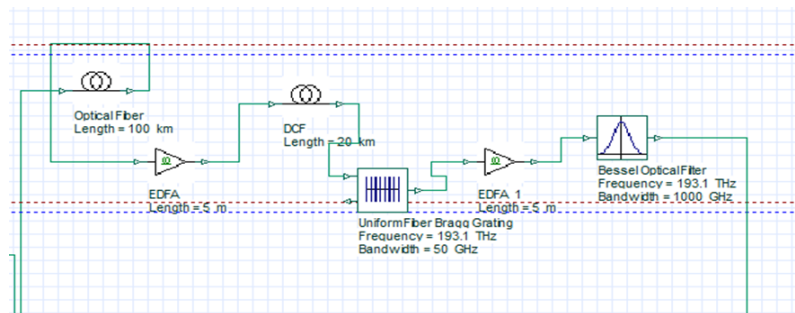

Figure 4.21: Simulation of proposed WDM-RoF System with Uniform FBG in an optical medium

Figure 4.21. shows the simulation of proposed WDM-RoF system with Uniform FBG. In Uniform FBG the grating period varies uniformly along the fiber axis. The Uniform FBG is placed in the transmission medium for achieving the long-distance transmission with less distortion.

### 4.3.1 Results of 32 channel WDM-RoF system with Uniform FBG

Figure 4.22- 4.24. shows the eye diagram for channels 8,16,32 with Uniform FBG having a channel spacing of 50 GHz with an input power of -5 dBm for a transmission distance of 120 km. While varying the structure into a uniform FBG, the q-factor for channel 32 is 18.71 which is much better than with and without FBG schemes.

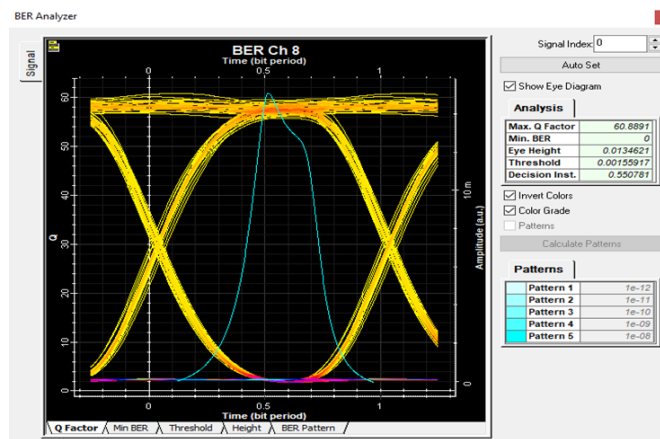

Figure 4.22: Eye diagram for channel 8 at 50 GHz channel spacing for traversal of 120 km

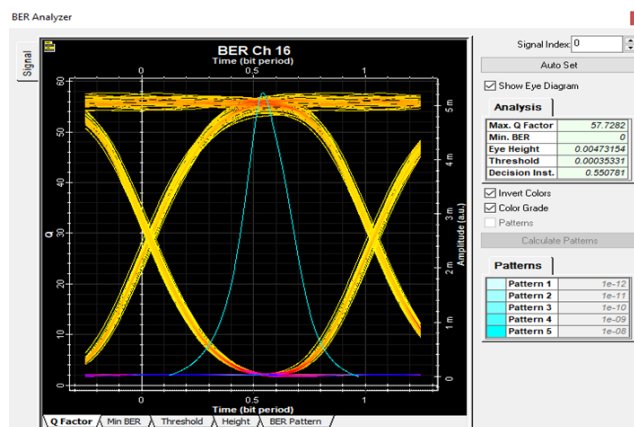

Figure 4.23: Eye diagram for channel 16 at 50 GHz channel spacing for traversal of 120 km

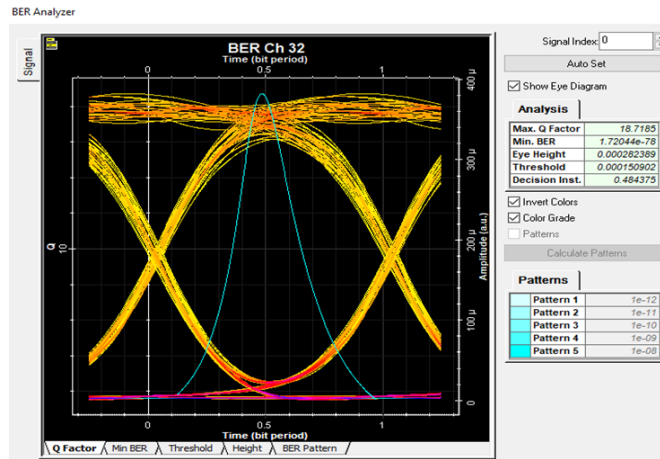

Figure 4.24: Eye diagram for channel 32 at 50 GHz channel spacing for traversal of 120 km

### 4.4 Comparison Chart

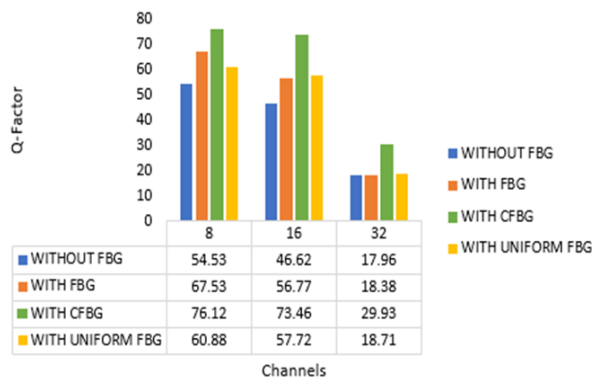

Figure 4.25: Performance Comparison with FBG, Chirped FBG, Uniform FBG without FBG

The performance comparison of our proposed system with 6 Gbps per channel bitrate at signal power of -5 dBm for 120 km transmission is illustrated in Figure 4.25. From this chart we concluded that by changing the grating structure of an FBG, the overall performance of the system is enhanced. And the Chirped FBG structure should attain a highest Q-factor and lowest BER. WDM based RoF link with CFBG has almost similar characteristics as compared WDM-RoF system with FBG. But the WDM based RoF link with CFBG has better performance in terms of its Q-factor. In optical communication systems, linear chirped fiber gratings (LCFG) are a crucial dispersion compensation technique. Although there are many benefits to linearly chirped fiber gratings, including large and stable dispersion, adjustable bandwidth.

# Chapter 5

## Conclusion

In order to make the suggested system affordable, and wide-bandwidth, a Radio over Fiber system has been built, simulated using the optisystem version 20.0 software, and its properties, such as Q-factor and BER, have been compared. The most realistic design parameters that have been created for the new WDM RoF system are used, hence we choose to include FBG in the proposed work. The suggested 32 channel WDM-RoF system, which incorporates DCF and FBG as dispersion compensators and is capable of transmitting data at a rate of 6 Gbps per channel with an input power of -5 dBm has been successfully simulated and studied in this study across a distance of 120 km. After transmitting across 32 channels, a maximum Q factor of 18.38 was attained at a channel spacing of 50 GHz for a distance of 120 km, respectively.

We modify an FBG's grating structure into a chirped and uniform for giving better performance in the system. Fiber that has been chirped due to their enormous potential for usage as dispersion equalizers in long-distance fiber telecom network. At the 32-channel WDM long-haul network, the Chirped FBG approach has been introduced and is now being researched based on Eye diagrams. So, we concluded that by changing the grating structure of an FBG, the overall performance of the system is enhanced. And the Chirped FBG structure should attain a highest Q-factor of 29.93 while operated in 32 channel mode. WDM based RoF link with CFBG has almost similar characteristics as compared WDM-RoF system with FBG. Uniform FBG should also gives better performance than FBG. Thus, it can be concluded that, proposed system is significantly more effective for long-haul transmission.

# Chapter 6

## Future Scope

In recent decades, the demand for wireless communication has risen. Fifth-generation (5G) communications, which offer a lot more functionality than fourth-generation (4G) communications, will soon be available. Beyond 5G, there are a number of significant issues that must be handled, including improved quality of service (QoS), higher security, faster system capacity, faster data rates, and reduced latency. A 5G network system must be smarter and more adaptable in order to satisfy varied network requirements. One of the primary challenges with 5G is the inability to provide users of devices with greater data rates with the necessary capacity. The requirements can be satisfied by introducing FBG in a 5G Front haul link. FBG can also be implemented as Wavelength remodulation for increasing the number of users in the system and thereby reducing the cost of the system.

# References

- [1] F. Laghezza, F. Scotti, P. Ghelfi, A. Bogoni, Photonics-assisted multiband rf transceiver for wireless communications, *J. Lightwave Technol.* 32 (16) (2014) 2896–2904.
- [2] V.A. Thomas, S. Ghafoor, M. El-Hajjar, L. Hanzo, A full-duplex diversity-assisted hybrid analogue/digitized radio over fibre for optical/wireless integration, *IEEE Commun. Lett.* 17 (2) (2013) 409–412
- [3] S. Mohanty, A. Agarwal, K. Agarwal, S. Mali, and G. Misra, “Role of millimeter wave for future 5g mobile networks: Its potential, prospects and challenges,” in 2021 1st Odisha International Conference on Electrical Power Engineering, Communication and Computing Technology(ODICON), 2021, pp. 1–4.
- [4] R. Puerta, J. Yu, X. Li, Y. Xu, J. J. Vegas Olmos, and I. Tafur Monroy, “Single-carrier dual-polarization 328-gb/s wireless transmission in a d-band millimeter wave  $2 \times 2$  mu-mimo radio-over-fiber system,” *Journal of Lightwave Technology*, vol. 36, no. 2, pp. 587–593, 2018.
- [5] R. Bhattacharjee, P. Dey and A. Saha, “ Implementation of an enhanced 32 channel 256 Gbps DWDM based Radio over Fiber optical system for constricted channel spacing employing Fiber Bragg Grating ”in *International Journal for Light and Electron Optics* 253(2022) 0030-4026/© 2022 Elsevier GmbH. <https://doi.org/10.1016/j.ijleo.2022.168598>
- [6] N. Kathpal, A. Kumar Garg, “Analysis of Radio over Fiber system for mitigating four-wave mixing effect”, *Digit. Commun. Netw.* 6 (1) (2020)

- [7] Munshid, Mohammed, "Design And Simulation of External Modulation Technique Based on Radio Over Fiber (RoF) Communication System", International Journal of Engineering Sciences Research Technology. 6 . 702-709 (2017).Doi:10.5281/zenodo.834460
- [8] H. Ahmed, R. khlf, " Radio over Fiber Performance Evaluation in Optical Communication System Utilizing FBG under Different DCF Schemes for DPSK Format "in Journal of Engineering and Applied Sciences 14(4):1130-113.Doi:10.3923/jeasci.2019.1130.1137.
- [9] M.Chakkour, O.Aghzout, B.Ahmed, "Chromatic Dispersion Compensation Effect Performance Enhancements Using FBG and EDFA-Wavelength Division Multiplexing Optical Transmission System ".in International Journal of Optics Volume 2017 doi: org/10.1155/2017/6428972
- [10] G. Kaur, R.S. Kalar "Wavelength Remodulation and Dispersion Compensation for Full-duplex Radio over Fiber System using Fiber Bragg Grating", Optik (2020),in International Journal for Light and Electron Optics 206 (2020) doi: <https://doi.org/10.1016/j.ijleo.2019.163223>.
- [11] Fahd CHAOUI<sup>3</sup>, Otman AGHZOUT<sup>1</sup>, IEEE Member, Ana Vazquez ALEJOS, IEEE Member, Francisco FALCONE, IEEE Senior Member, Mounia CHAKKOUR, Mounir EL YAKHLOUFI," Reduction of Four Wave Mixing Effect in DWDM Long Haul Optical Networks",2016 IEEE , DOI: 10.1109/ICMCS.2016.790557
- [12] A. Mohan A.P. Anisha, " Full duplex transmission in RoF system using WDM OADM technology " in International Journal of Engineering Research Technology (IJERT) ISSN: 2278-0181Vol. 4 Issue 01,January-2015www.ijert.org
- [13] M.A. Othman, M.M. Ismail," An Analysis of 10 Gbits/s Optical Transmission System using Fiber Bragg Grating (FBG)" in IOSR Journal of Engineering (IOSR-JEN)ISSN: 2250-3021 Volume 2, Issue 7(July 2012), PP 55-61.
- [14] G. Pandey, A. Choudhary and A. Dixit, "Wavelength Division Multiplexed Radio Over Fiber Links for 5G Fronthaul Networks," in IEEE Journal on Se-

lected Areas in Communications, vol. 39, no. 9, pp. 2789-2803, Sept. 2021, doi: 10.1109/JSAC.2021.3064654.

- [15] Yingxiong Song, Peihua Yu, Yan Xu, Zhengxuan Li, “Simulation and experimental investigation of nonlinear effects in 5G fronthaul transmission system based on WDM-PON architecture” 1068-5200/© 2021 Elsevier Inc. All rights reserved. DOI: 10.1016/j.yofte.2021.1